

53-1002919-01
26 July 2013



Access Gateway

Administrator's Guide

Supporting Fabric OS v7.2.0

BROCADE

Copyright © 2013 Brocade Communications Systems, Inc. All Rights Reserved.

ADX, AnyIO, Brocade, Brocade Assurance, the B-wing symbol, DCX, Fabric OS, ICX, MLX, MyBrocade, OpenScript, VCS, VDX, and Vyatta are registered trademarks, and HyperEdge, The Effortless Network, and The On-Demand Data Center are trademarks of Brocade Communications Systems, Inc., in the United States and/or in other countries. Other brands, products, or service names mentioned may be trademarks of their respective owners.

Notice: This document is for informational purposes only and does not set forth any warranty, expressed or implied, concerning any equipment, equipment feature, or service offered or to be offered by Brocade. Brocade reserves the right to make changes to this document at any time, without notice, and assumes no responsibility for its use. This informational document describes features that may not be currently available. Contact a Brocade sales office for information on feature and product availability. Export of technical data contained in this document may require an export license from the United States government.

The authors and Brocade Communications Systems, Inc. shall have no liability or responsibility to any person or entity with respect to any loss, cost, liability, or damages arising from the information contained in this book or the computer programs that accompany it.

The product described by this document may contain "open source" software covered by the GNU General Public License or other open source license agreements. To find out which open source software is included in Brocade products, view the licensing terms applicable to the open source software, and obtain a copy of the programming source code, please visit <http://www.brocade.com/support/oscd>.

Brocade Communications Systems, Incorporated

Corporate and Latin American Headquarters
Brocade Communications Systems, Inc.
130 Holger Way
San Jose, CA 95134
Tel: 1-408-333-8000
Fax: 1-408-333-8101
E-mail: info@brocade.com

Asia-Pacific Headquarters
Brocade Communications Systems China HK, Ltd.
No. 1 Guanghua Road
Chao Yang District
Units 2718 and 2818
Beijing 100020, China
Tel: +8610 6588 8888
Fax: +8610 6588 9999
E-mail: china-info@brocade.com

European Headquarters
Brocade Communications Switzerland Sàrl
Centre Swissair
Tour B - 4ème étage
29, Route de l'Aéroport
Case Postale 105
CH-1215 Genève 15
Switzerland
Tel: +41 22 799 5640
Fax: +41 22 799 5641
E-mail: emea-info@brocade.com

Asia-Pacific Headquarters
Brocade Communications Systems Co., Ltd. (Shenzhen WFOE)
Citic Plaza
No. 233 Tian He Road North
Unit 1308 - 13th Floor
Guangzhou, China
Tel: +8620 3891 2000
Fax: +8620 3891 2111
E-mail: china-info@brocade.com

Document History

Document title	Publication number	Summary of changes	Publication date
<i>Access Gateway Administrator's Guide</i>	53-1000430-01	First version.	January 2007
<i>Access Gateway Administrator's Guide</i>	53-1000633-01	Added support for the 200E.	June 2007
<i>Access Gateway Administrator's Guide</i>	53-1000605-01	Added support for new policies and changes to N_Port mappings.	October 2007
<i>Access Gateway Administrator's Guide</i>	53-1000605-02	Added support for the 300 and 4424 models. Added support for new features: - Masterless Trunking - Direct Target Connectivity - Advance Device Security policy - 16- bit routing	March 2008
<i>Access Gateway Administrator's Guide</i>	53-1000605-03	Added support for Cascading Access Gateway.	July 2008
<i>Access Gateway Administrator's Guide</i>	53-1000605-04	Updated to fix the table of contents.	July 2008
<i>Access Gateway Administrator's Guide</i>	53-1001189-01	Updated for Fabric OS v6.2.0.	November 2008
<i>Access Gateway Administrator's Guide</i>	53-1001345-01	Updated for Fabric OS v6.3.0.	July 2009
<i>Access Gateway Administrator's Guide</i>	53-1001760-01	Updated for Fabric OS v6.4.0.	March 2010
<i>Access Gateway Administrator's Guide</i>	53-1002156-01	Updated for Fabric OS v7.0.0.	April 2011
<i>Access Gateway Administrator's Guide</i>	53-1002475-01	Updated for Fabric OS v7.0.1.	December 2011
<i>Access Gateway Administrator's Guide</i>	53-1002743-01	Updated for Fabric OS v7.1.0	December 2012
<i>Access Gateway Administrator's Guide</i>	53-1002919-01	New document for Fabric OS v7.2.0	July 2012

Contents

About This Document

How this document is organized	xiii
Supported hardware and software	xiv
What's new in this document	xiv
Document conventions	xv
Text formatting	xv
Command syntax conventions	xv
Notes, cautions, and warnings	xvi
Notice to the reader	xvi
Key terms for Access Gateway	xvii
Additional information	xviii
Brocade resources	xviii
Other industry resources	xviii
Optional Brocade features	xviii
Getting technical help	xix
Document feedback	xix

Chapter 1

Access Gateway Basic Concepts

Brocade Access Gateway overview	1
Comparing Native Fabric and Access Gateway modes	1
Fabric OS features in Access Gateway mode	3
Buffer credit recovery support	6
Forward error correction support	6
Virtual Fabrics support	6
Device authentication support	6
Access Gateway port types	9
Comparison of Access Gateway ports to standard switch ports	9
Access Gateway hardware considerations	11

Chapter 2

Configuring Ports in Access Gateway Mode

Enabling and disabling Access Gateway mode	13
Port state description	14

Access Gateway mapping	15
Port mapping	16
F_Port Static Mapping	21
Device mapping	22
Considerations for Access Gateway mapping	28
N_Port configurations	30
Displaying N_Port configurations	31
Unlocking N_Ports	31
Persisting port online state	31
D_Port support	32
Limitations and considerations	33
Saving port mappings	33

Chapter 3 Managing Policies and Features in Access Gateway Mode

Access Gateway policies overview	35
Displaying current policies	35
Access Gateway policy enforcement matrix	36
Advanced Device Security policy	36
How the ADS policy works	36
Enabling and disabling the ADS policy	37
Allow lists	37
ADS policy considerations	39
Upgrade and downgrade considerations for the ADS policy	39
Automatic Port Configuration policy	39
How the APC policy works	39
Enabling and disabling the APC policy	40
APC policy considerations	40
Upgrade and downgrade considerations for the APC policy	40
Port Grouping policy	41
How port groups work	41
Adding an N_Port to a port group	42
Deleting an N_Port from a port group	42
Removing a port group	42
Renaming a port group	43
Disabling the Port Grouping policy	43
Port Grouping policy modes	43
Creating a port group and enabling Automatic Login	
Balancing mode	44
Enabling MFNM mode	45
Disabling MFNM mode	45
Displaying the current MFNM mode timeout value	46
Setting the current MFNM mode timeout value	46
Port Grouping policy considerations	46
Upgrade and downgrade considerations for the Port	
Grouping policy	47
Device Load Balancing policy	47
Enabling the Device Load Balancing policy	47
Disabling the Device Load Balancing policy	47
Device Load Balancing policy considerations	48

Persistent ALPA policy	48
Enabling the Persistent ALPA policy	48
Disabling the Persistent ALPA policy.	49
Persistent ALPA device data	49
Clearing ALPA values	50
Persistent ALPA policy considerations	50
Failover policy	50
Failover with port mapping	50
Failover with device mapping	53
Enabling and disabling the Failover policy on an N_Port	54
Enabling and disabling the Failover policy for a port group	54
Upgrade and downgrade considerations for the Failover policy.	55
Failback policy.	55
Failback policy configurations in Access Gateway.	55
Enabling and disabling the Failback policy on an N_Port	56
Enabling and disabling the Failback policy for a port group.	57
Upgrade and downgrade considerations for the Failback policy.	57
Failback policy disabled on unreliable links (N_Port monitoring).	57
Trunking in Access Gateway mode.	58
How trunking works	58
Configuring trunking on the Edge switch	58
Configuration management for trunk areas	59
Enabling trunking.	61
Disabling F_Port trunking	61
Monitoring trunking.	61
AG trunking considerations for the Edge switch	62
Trunking considerations for Access Gateway mode	65
Upgrade and downgrade considerations for trunking in Access Gateway mode	65
Adaptive Networking on Access Gateway	65
QoS: Ingress rate limiting	66
QoS: SID/DID traffic prioritization.	66
Upgrade and downgrade considerations for Adaptive Networking in AG mode.	66
Adaptive Networking on Access Gateway considerations.	67
Per-Port NPIV login limit	67
Setting the login limit.	67
Duplicate PWWN handling during device login.	68
Performance Monitoring.	68
Flow Monitor.	68
Legacy performance monitoring features	69
Considerations for the Brocade 6505 and 6510	71

Chapter 4	SAN Configuration with Access Gateway	
	Connectivity of multiple devices overview	73
	Considerations for connecting multiple devices	73
	Direct target attachment	74
	Considerations for direct target attachment	74
	Target aggregation	75
	Access Gateway cascading	76
	Access Gateway cascading considerations	76
	Fabric and Edge switch configuration	77
	Verifying the switch mode	77
	Enabling NPIV on M-EOS switches	78
	Connectivity to Cisco fabrics	78
	Enabling NPIV on a Cisco switch	78
	Rejoining Fabric OS switches to a fabric	79
	Reverting to a previous configuration	79
Appendix A	Troubleshooting	
Index		

Figures

- Figure 1** Switch function in Native mode 2
- Figure 2** Switch function in Access Gateway mode 3
- Figure 3** Port usage comparison 10
- Figure 4** Diagnostic port configurations 10
- Figure 5** Port mapping example 16
- Figure 6** Example of device mapping to N_Port groups. 23
- Figure 7** Example device mapping to an N_Port 24
- Figure 8** Example of adding an external F_Port (F9) on an embedded switch 30
- Figure 9** Port grouping behavior 41
- Figure 10** Port group 1 (PG1) setup 42
- Figure 11** Failover behavior 52
- Figure 12** Failback behavior. 56
- Figure 13** Starting point for QoS 66
- Figure 14** Direct target attachment to switch operating in AG mode 74
- Figure 15** Target aggregation. 75
- Figure 16** Access Gateway cascading. 76

Tables

Table 1	Fabric OS components supported on Access Gateway	3
Table 2	Behavior of sending AG switch and receiving fabric switch with different policies configured	8
Table 3	Behavior of sending device (HBA) and receiving AG switch with different policies configured	8
Table 4	Port configurations	11
Table 5	Port state description	14
Table 6	Description of port mapping	16
Table 7	Access Gateway default port mapping	17
Table 8	Policy enforcement matrix	36
Table 9	Address identifier	60
Table 10	Access Gateway trunking considerations for the Edge switch	62
Table 11	PWWN format for F_Port and N_Port trunk ports.	65
Table 12	Troubleshooting	81

About This Document

- [How this document is organized](#) xiii
- [Supported hardware and software](#)..... xiv
- [What’s new in this document](#)..... xiv
- [Document conventions](#) xv
- [Notice to the reader](#) xvi
- [Key terms for Access Gateway](#) xvii
- [Additional information](#)..... xviii
- [Getting technical help](#) xix
- [Document feedback](#) xix

How this document is organized

This document is a procedural guide to help SAN administrators configure and manage Brocade Access Gateway (AG).

This preface contains the following components:

- [Chapter 1, “Access Gateway Basic Concepts”](#) describes the Brocade Access Gateway and provides an overview of its key features.
- [Chapter 2, “Configuring Ports in Access Gateway Mode”](#) describes how to configure ports in Access Gateway mode.
- [Chapter 3, “Managing Policies and Features in Access Gateway Mode”](#) describes how to enable policies on a switch in Access Gateway mode. It also provides information on how to set up failover and failback, and discusses how trunking and Adaptive Networking work in AG.
- [Chapter 4, “SAN Configuration with Access Gateway”](#) describes how to connect multiple devices using Access Gateway.
- [Appendix A, “Troubleshooting”](#) provides symptoms and troubleshooting tips to resolve issues.

Supported hardware and software

In those instances in which procedures or parts of procedures documented here apply to some switches but not to others, this guide identifies which switches are supported and which are not.

Although many different software and hardware configurations are tested and supported by Brocade Communications Systems, Inc., for Fabric OS v7.1.0, documenting all possible configurations and scenarios is beyond the scope of this document.

All Fabric OS switches must be running Fabric OS v6.1.0 or later; all M-EOS switches must be running M-EOSc 9.1 or later, M-EOSn must be running 9.6.2 or later, and Cisco switches with NX OS must be running 5.x or later.

Fabric OS v7.1.0 supports the following Brocade hardware platforms for Access Gateway:

- Brocade 300
- Brocade 5100
- Brocade M5424
- Brocade 5430
- Brocade 5431
- Brocade 5450
- Brocade 5460
- Brocade 5470
- Brocade 5480
- Brocade 6505
- Brocade M6505
- Brocade 6510
- Brocade 6547
- NC-4380
- Brocade VA-40FC

What's new in this document

The following information has been added since this document was last released:

- Preface
 - [“Supported hardware and software”](#) on page xiv updated to add support for Brocade 6547, M6505, 5431 and remove support for Brocade 8000 switch.
- Chapter 2
 - Default F_Port to N_Port mapping under [“Port mapping”](#) on page 16 updated for Brocade 6547, M6505, and 5431 switches.
 - Removed “Brocade 8000 mapping differences” section.
 - [“D_Port support”](#) on page 32 updated to include support for D_Port on connected HBA.

- Chapter 3
 - Added new section, “[Duplicate PWWN handling during device login](#)” on page 68.
 - Removed “Considerations for the Brocade 8000” section.
 - Added support for **portcfgtrunkport** command in Access Gateway.
- Appendix A
 - Removed “Login Rejected by FC stack” problem for Brocade 8000.

For further information, refer to the release notes.

Document conventions

This section describes text formatting conventions and important notices formats.

Text formatting

The narrative-text formatting conventions that are used in this document are as follows:

bold text	Identifies command names Identifies the names of user-manipulated GUI elements Identifies keywords and operands Identifies text to enter at the GUI or CLI
<i>italic text</i>	Provides emphasis Identifies variables Identifies paths and Internet addresses Identifies document titles
<code>code text</code>	Identifies CLI output Identifies syntax examples

For readability, command names in the narrative portions of this guide are presented in mixed lettercase: for example, **switchShow**. In actual examples, command lettercase is often all lowercase.

Command syntax conventions

Command syntax in this manual follows these conventions:

command	Commands are printed in bold.
--option, option	Command options are printed in bold.
-argument, arg	Arguments.
[]	Optional element.
<i>variable</i>	Variables are printed in italics. In the help pages, values are <u>underlined</u> or enclosed in angled brackets < >.

... Repeat the previous element, for example “member[;member...]”

value Fixed values following arguments are printed in plain font. For example, `--show WWN`

| Boolean. Elements are exclusive. Example: `--show -mode egress | ingress`

Notes, cautions, and warnings

The following notices appear in this document.

NOTE

A note provides a tip, guidance, or advice, emphasizes important information, or provides a reference to related information.

ATTENTION

An Attention statement indicates potential damage to hardware or data.



CAUTION

A Caution statement alerts you to situations that can be potentially hazardous to you or cause damage to hardware, firmware, software, or data.



DANGER

A Danger statement indicates conditions or situations that can be potentially lethal or extremely hazardous to you. Safety labels are also attached directly to products to warn of these conditions or situations.

Notice to the reader

This document may contain references to the trademarks of the following corporations. These trademarks are the properties of their respective companies and corporations.

These references are made for informational purposes only.

Corporation	Referenced trademarks and products
Cisco Systems, Inc.	Cisco
Oracle Corporation.	Sun, Solaris
Netscape Communications Corporation	Netscape
Red Hat, Inc.	Red Hat, Red Hat Network, Maximum RPM, Linux Undercover
Emulex Corporation	Emulex
QLogic Corporation	QLogic

Key terms for Access Gateway

For definitions of SAN-specific terms, visit the Storage Networking Industry Association online dictionary at:

<http://www.snia.org/education/dictionary>

For definitions specific to Brocade and Fibre Channel, see the *Brocade Glossary*.

The following terms are used in this manual to describe Access Gateway mode and its components.

Access Gateway (AG) Fabric OS mode for switches that reduces storage area network (SAN) deployment complexity by leveraging N_Port ID Virtualization (NPIV).

Device Any host or target device with a distinct WWN. Devices may be physical or virtual.

D_Port A port configured as a diagnostic port on an AG switch, connected fabric switch, or connected cascaded AG switch to run diagnostic tests between the ports and test the link.

E_Port An interswitch link (ISL) port. A switch port that connects switches together to form a fabric.

Edge switch A fabric switch that connects host, storage, or other devices, such as Brocade Access Gateway, to the fabric.

F_Port A fabric port. A switch port that connects a host, host bus adapter (HBA), or storage device to the SAN. On Brocade Access Gateway, the F_Port connects to a host or a target.

Mapping In Access Gateway, mapping defines the routes between devices or F_Ports to the fabric facing ports (N_Ports).

N_Port A node port. A Fibre Channel host or storage port in a fabric or point-to-point connection. On Brocade Access Gateway, the N_Port connects to the Edge switch.

NPIV N_Port ID Virtualization. This is a Fibre Channel facility allowing multiple N_Port IDs to share a single physical N_Port. This allows multiple Fibre Channel initiators to occupy a single physical port, easing hardware requirements in storage area network design, especially for virtual SANs.

Additional information

This section lists additional Brocade and industry-specific documentation that you might find helpful.

Brocade resources

To get up-to-the-minute information, go to <http://my.brocade.com> to register at no cost for a user ID and password.

White papers, online demonstrations, and data sheets are available through the Brocade website at:

<http://www.brocade.com/products-solutions/products/index.page>

For additional Brocade documentation, visit the Brocade website:

<http://www.brocade.com>

Release notes are available on the MyBrocade website and are also bundled with the Fabric OS firmware.

Other industry resources

- White papers, online demonstrations, and data sheets are available through the Brocade website at <http://www.brocade.com/products-solutions/products/index.page>.
- Best practice guides, white papers, data sheets, and other documentation are available through the Brocade Partner website.

For additional resource information, visit the Technical Committee T11 website. This website provides interface standards for high-performance and mass storage applications for Fibre Channel, storage management, and other applications:

<http://www.t11.org>

For information about the Fibre Channel industry, visit the Fibre Channel Industry Association website:

<http://www.fibrechannel.org>

Optional Brocade features

For a list of optional Brocade features and descriptions, see the *Fabric OS Administrator's Guide*.

Getting technical help

Contact your switch support supplier for hardware, firmware, and software support, including product repairs and part ordering. To expedite your call, have the following information available:

1. General Information

- Technical Support contract number, if applicable
- Switch model
- Switch operating system version
- Error numbers and messages received
- **supportSave** command output
- Detailed description of the problem, including the switch or fabric behavior immediately following the problem, and specific questions
- Description of any troubleshooting steps already performed and the results
- Serial console and Telnet session logs
- Syslog message logs

2. Switch Serial Number

The switch serial number and corresponding bar code are provided on the serial number label, as shown here:



The serial number label is located as follows:

- *Brocade 300, 5100, VA-40FC, 6505, and 6510*—On the switch ID pull-out tab located inside the chassis on the port side on the left
- *Brocade M5424, 5430, 5431, 5450, 5460, 5470, 5480, 6547, M6505,* —Serial number label attached to the module

3. World Wide Name (WWN)

Use the **licenseIdShow** command to display the WWN of the chassis.

If you cannot use the **licenseIdShow** command because the switch is inoperable, you can get the WWN from the same place as the serial number.

Document feedback

Quality is our first concern at Brocade and we have made every effort to ensure the accuracy and completeness of this document. However, if you find an error or an omission, or you think that a topic needs further development, we want to hear from you. Forward your feedback to:

documentation@brocade.com

Provide the title and version number of the document and as much detail as possible about your comment, including the topic heading and page number and your suggestions for improvement.

Access Gateway Basic Concepts

- [Brocade Access Gateway overview](#) 1
- [Fabric OS features in Access Gateway mode](#) 3
- [Access Gateway port types](#) 9
- [Access Gateway hardware considerations](#) 11

Brocade Access Gateway overview

Brocade Access Gateway (AG) is a Fabric OS feature that you can use to configure your Enterprise fabric to handle additional devices instead of domains. You do this by configuring F_Ports to connect to the fabric as N_Ports, which increases the number of device ports you can connect to a single fabric. Multiple AGs can connect to the DCX enterprise-class platform, directors, and switches.

Access Gateway is compatible with M-EOS v9.1 or v9.6 or later, and Cisco-based fabrics v3.0 (1) or later and v3.1 (1) or later. You can use the command line interface (CLI), Web Tools, or Brocade Network Advisor (BNA) to enable and disable AG mode and configure AG features on a switch. This document describes configurations using the CLI commands. Refer to the *Fabric OS Command Reference Manual*, the *Web Tools Administrator's Guide*, or the *Brocade Network Advisor User Guide* for more information about AG support in those tools.

After you set a Fabric OS switch to AG mode, the F_Ports connect to the Enterprise fabric as N_Ports rather than as E_Ports. [Figure 1](#) shows a comparison of a configuration that connects eight hosts to a fabric using AG to the same configuration with Fabric OS switches in Native mode.

Switches in AG mode are logically transparent to the host and the fabric. Therefore, you can increase the number of hosts that have access to the fabric without increasing the number of switch domains. This simplifies configuration and management in a large fabric by reducing the number of domain IDs and ports.

Comparing Native Fabric and Access Gateway modes

The following points summarize the differences between a Fabric OS switch functioning in Native operating mode and a Fabric OS switch functioning in AG operating mode:

- The Fabric OS switch in Native mode is a part of the fabric; it requires two to four times as many physical ports, consumes fabric resources, and can connect to a Fabric OS fabric only.
- A switch in AG mode is outside of the fabric; it reduces the number of switches in the fabric and the number of required physical ports. You can connect an AG switch to a Fabric OS, M-EOS, or Cisco-based fabric.

1 Brocade Access Gateway overview

For comparison, [Figure 1](#) illustrates switch function in Native mode and [Figure 2](#) illustrates switch function in AG mode.

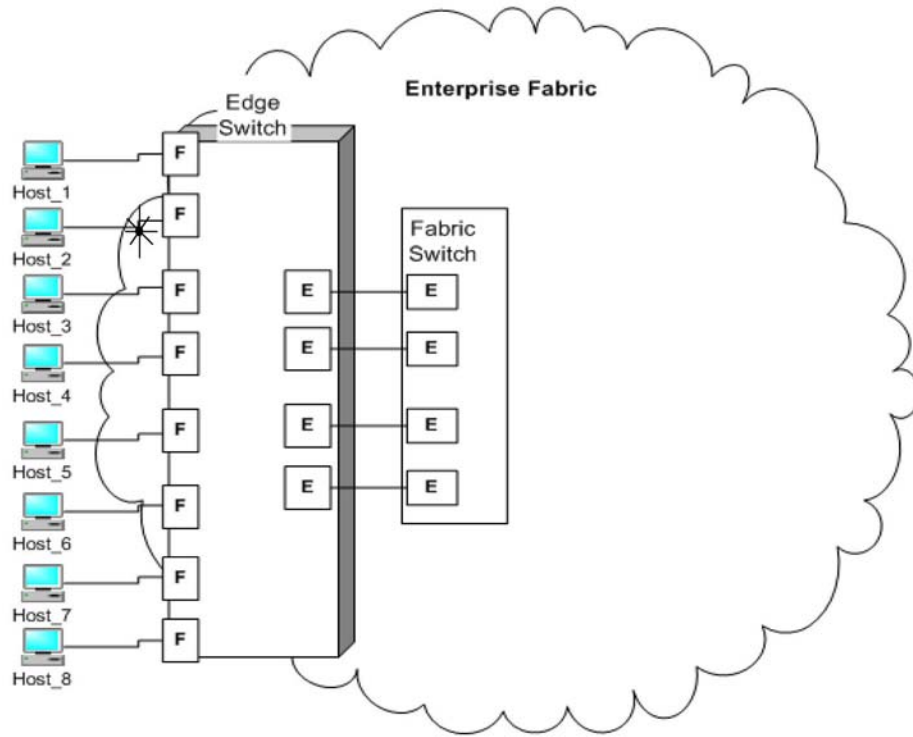

FIGURE 1 Switch function in Native mode

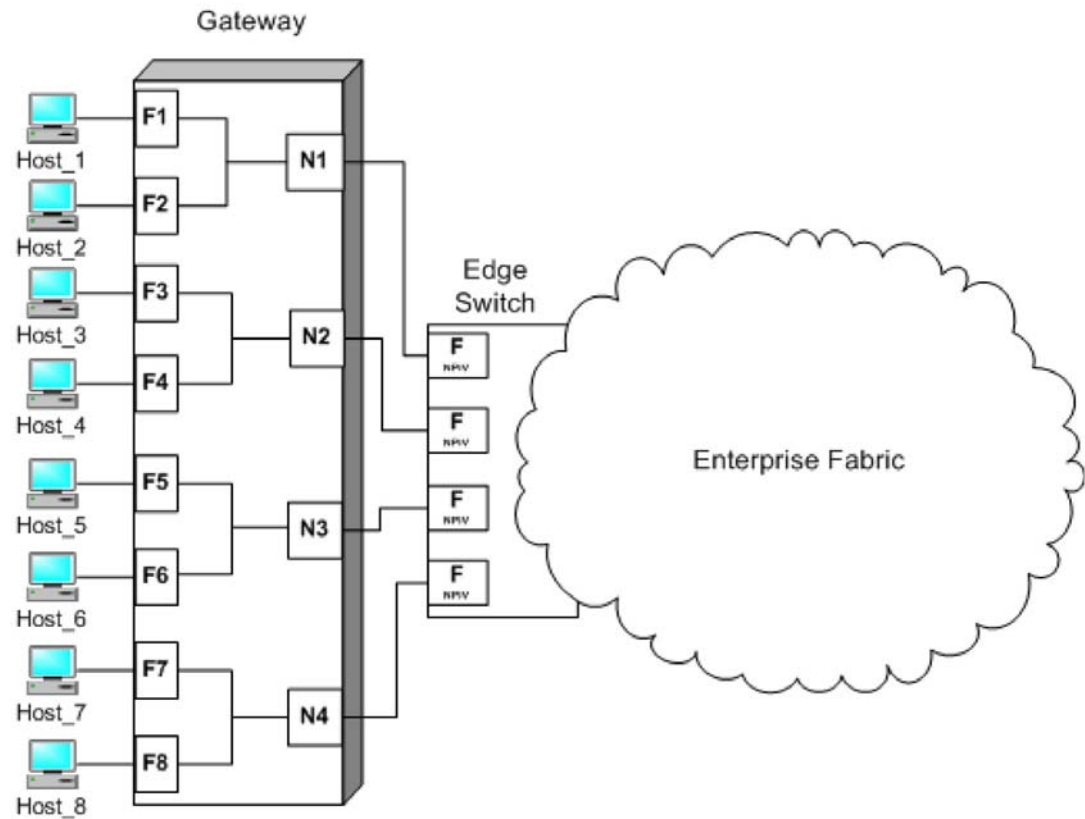

FIGURE 2 Switch function in Access Gateway mode

Fabric OS features in Access Gateway mode

Table 1 lists Fabric OS components that are supported on a switch when AG mode is enabled. “Yes” indicates that the feature is supported in Access Gateway mode. “No” indicates that the feature is not provided in AG mode. “NA” indicates the feature is not applicable in Access Gateway mode. A single asterisk (*) indicates the feature is transparent to AG; that is, AG forwards the request to the Enterprise fabric. Two asterisks (**) indicates that the feature may not be available if the Enterprise fabric is not a Brocade fabric. For more information on these features, refer to the *Fabric OS Administrator's Guide* and *Fabric OS Command Reference*.

TABLE 1 Fabric OS components supported on Access Gateway

Feature	Support
Access Control ¹	Yes (limited roles)
Adaptive Networking	Yes
Admin Domains	No
Audit	Yes
Beaconing	Yes
Bottleneck Detection	Yes

1 Fabric OS features in Access Gateway mode

TABLE 1 Fabric OS components supported on Access Gateway (Continued)

Feature	Support
Buffer Credit Recovery (CR)	Yes - Refer to “Buffer credit recovery support” on page 6.
Config Download/Upload	Yes
Device Authentication	Yes Refer to “Device authentication support” on page 6.
DHCP	Yes
Diagnostic Port (D_Port)	Yes Refer to “D_Port support” on page 32.
Duplicate PWWN handling during device login	Yes Refer to “Duplicate PWWN handling during device login” on page 68.
Encryption Configuration and Management	No
Environmental Monitor	Yes
Error Event Management	Yes
Extended Fabrics	No
Fabric Assigned PWWN (FA-PWWN)	Yes
Fabric Device Management Interface (FDMI)	Yes*
Fabric Manager	Yes**
Fabric Provisioning	No
Fabric Services	No
Fabric Watch	Yes Refer to the <i>Fabric Watch Administrator's Guide</i> for applicable support details.
Fibre Channel Routing (FCR) services	No
FICON (includes CUP)	No
Forward Error Correction (FEC)	Yes Refer to “Forward error correction support” on page 6.
High Availability	Yes
Hot Code Load	Yes
License	Yes**
Lightweight Directory Access Protocol (LDAP)	Yes
Log Tracking	Yes
Management Server	NA

TABLE 1 Fabric OS components supported on Access Gateway (Continued)

Feature	Support
Manufacturing Diagnostics	Yes
N_Port ID Virtualization (NPIV)	Yes
Name Server	NA
Native Interoperability Mode	NA
Network Time Protocol (NTP)	No (no relevance from fabric perspective) ²
Open E_Port	NA
Performance Monitor	Yes
Persistent ALPA	Yes
Port Decommission	No
Port Mirroring	No
QuickLoop, QuickLoop Fabric Assist	No
Remote Authentication Dial-In User Service (RADIUS)	Yes
Resource Monitor	Yes
Security	Yes (ADS/DCC Policy)
SNMP	Yes
Speed Negotiation	Yes
Syslog Daemon	Yes
Track Changes	Yes
Trunking	Yes**
User-Defined Roles	Yes
ValueLineOptions (Static POD, DPOD)	Yes
Virtual Fabrics	No Refer to “Virtual Fabrics support” on page 6.
Web Tools	Yes
Zoning	NA

1. When a switch is behaving as an AG, RBAC features in Fabric OS are available, but there are some limitations. For more information on the limitations, refer to [“Access Gateway hardware considerations”](#) on page 11.
2. In embedded switches, time should be updated by the server management utility.

Buffer credit recovery support

This Fabric OS feature is supported on 8 Gbps and 16 Gbps platforms in following configurations:

- Between AG switch F_Port and Brocade HBA port using Adapter v3.2 or greater firmware or any device supporting credit recovery, This feature only works at the maximum supported speed of the HBA port (8 Gbps or 16 Gbps).
- Between AG switch N_Port and Brocade fabric switch or cascaded AG switch F_Port.

It is highly recommended that you disable this feature on the AG switch before connecting to a switch running Fabric OS less than 7.1. Enable and disable CR using the `portcfgcreditrecovery` command. Refer to the Fabric OS Command Reference for more information on this command.

Specific switch platforms support this feature either in R_RDY or VC_RDY mode. In VC_RDY mode, the buffer credit recovery is supported with fabric assigned PWWN (FA-PWWN), FEC, QoS, and trunking Fabric OS features. In R_RDY mode, this feature is supported without FA-PWWN and QoS Fabric OS features.

Forward error correction support

Forward error correction (FEC) is a Fabric OS feature supported in the following configurations:

- Between the AG switch F_Port and a Brocade 16 Gbps HBA port running version 3.2 or greater firmware.
- Between the AG switch N_Port and F_Port on Brocade 16 Gbps fabric switch or cascaded AG switch.

Following are limitations and considerations for FEC:

- Supported on Brocade 16 Gbps platforms only.
- Supported by Fabric OS 7.1.0 and later.
- Enabled by default.
- A Fabric OS downgrade requires FEC to be disabled.
- Specific switch platforms support this feature either in R_RDY or VC_RDY mode.

Virtual Fabrics support

Although you cannot enable AG mode on a switch enabled for Virtual Fabrics or enable Virtual Fabrics on an AG switch, you can connect ports on an AG switch to Virtual Fabrics.

Device authentication support

Devices use authentication as a mechanism to log in into switches only after exchanging DH_CHAP authorization keys. This prevents any unauthorized device from logging into switch and fabric by default.

Authentication policy is supported in the following configurations for Access Gateway switches. Regardless of the enabled policy, the AG port disables if the DH-CHAP or FCAP fails to authenticate each other.

- Access Gateway switch N_Port connected to Brocade fabric switch F_Port. The N_port should enable authentication when authentication is enabled on the connected switch. This can be done by enabling switch policy on the AG switch and device policy on the fabric switch.
- Access Gateway switch F_Port connected to an HBA. The F_Port also should enable authentication when the connected device is sending login request with authentication enabled. This is done by enabling device policy on the AG switch.

By default, Brocade switches use DH-CHAP or FCAP authentication protocols. For authentication between fabric switches and AG switches, FCAP and DH-CHAP are used. If an FCAP certificate is present on the AG switch and fabric switch, FCAP has precedence over DHCAP. For authentication between AG switches and HBAs, DH-CHAP is used since the HBA only supports DH-CHAP.

For details on installing FCAP certificates and creating DHCAP secrets on the switch in AG or native mode, refer to the *Fabric OS Administrator's Guide* or *Fabric OS Command Reference*.

For general information on authentication, refer to the section on authentication policy for fabric elements in the Configuring Security Policies chapter of the *Fabric OS Administrator's Guide*.

Supported policy modes

The following switch and device policy modes are supported by Access Gateway:

- On - Strict authentication will be enforced on all ports. The ports on the AG connected to the switch or device will disable if the connecting switch or device does not support authentication or the policy mode is set to off. During AG initialization, authentication initiates on all ports automatically.
- Off - The AG switch does not support authentication and rejects any authentication negotiation request from the connected fabric switch or HBA. A fabric switch with the policy mode set to off should not be connected to an AG switch with policy mode set to on since the on policy is strict. This will disable the port if any switch rejects the authentication. You must configure DH-CHAP shared secrets or install FCAP certificates on the AG and connected fabric switch before switching from a policy *off* mode to policy *on* mode. Off is the default mode for both switch and device policy.
- Passive - The AG does not initiate authentication when connected to a device, but participates in authentication if the connecting device initiates authentication. The AG will not initiate authentication on ports, but accepts incoming authentication requests. Authentication will not disable AG F_Ports if the connecting device does not support authentication or the policy mode is set to off. Passive mode is the safest mode to use for devices connected to an AG switch if the devices do not support authentication.

To perform authentication with switch policy, the on and off policy modes are supported on the AG switch. To perform authentication with device policy, the on, off, and passive modes are supported on the AG switch.

[Table 2](#) on page 8 describes the authentication behavior between a sending AG switch and receiving fabric switch.

1 Fabric OS features in Access Gateway mode

TABLE 2 Behavior of sending AG switch and receiving fabric switch with different policies configured

	Fabric switch with device policy mode ON	Fabric switch with device policy mode PASSIVE	Fabric switch with device policy mode OFF
AG switch with switch policy mode on	Authorization negotiation - accept DH-CHAP/FCAP: Success - N_Port Failure - disable	Authorization negotiation - accept DH-CHAP/FCAP: Success - N_Port Failure - disable	Authorization negotiation - reject N_Port without authentication
AG switch with switch policy off	No negotiation No light	No Negotiation N_Port without authentication.	No negotiation N_Port without authentication

Table 3 describes the authentication behavior between a sending HBA and receiving AG switch.

TABLE 3 Behavior of sending device (HBA) and receiving AG switch with different policies configured

	AG switch with device policy mode ON	AG switch with device policy mode PASSIVE	AG switch with device policy mode OFF
HBA authentication enabled	Authorization negotiation - accept DH-CHAP Success - F_Port Failure - disable	Authorization negotiation - accept DH-CHAP Success - F_Port Failure - disable	Authorization negotiation - reject F_Port without authentication
HBA authentication disabled	No negotiation No light	No negotiation F_Port without authentication	No negotiation F_Port without authentication

Supported Fabric OS commands

All Fabric OS commands for authentication policy apply to AG switches, including the following:

- authutil -- policy
- authutil --show
- authutil --set
- secauthsecret --set
- secauthsecret --show

NOTE

Although authutil --authinit is not supported in AG mode, it is supported in native mode.

For more information, refer to the *Fabric OS Command Reference*.

Limitations and considerations

- Authentication policy is not supported on cascaded AG switch configurations.
- Authentication is not supported between an AG switch running Fabric OS v7.1.0 or later and a fabric running Fabric OS earlier than v7.1.0. If the AG switch is connected to fabric switch running Fabric OS earlier than v7.1.0, the AG switch N_Ports will disable if authentication is enabled on both switches. Devices mapped to N_Ports connected to fabrics operating with Fabric OS before v7.1.0 will also disable.
- If authentication is disabled on the Fabric Switch, the AG switch N_Port will come online without authentication policy.
- Device and switch policies must be disabled on the AG before converting the switch to Native mode.
- Device and switch policies must be disabled on the switch in Native mode before converting it to AG mode.
- Authentication policy is disabled by default on all ports in AG mode.
- High availability (HA) reboots are supported.

Access Gateway port types

Access Gateway differs from a typical fabric switch because it is not a switch; instead, it is a mode that you enable on a switch using the **ag** command. After a switch is set in Access Gateway mode, it can connect to the fabric using node ports (N_Ports). Typically, fabric switches connect to the Enterprise fabric using interswitch link (ISL) ports, such as E_Ports.

AG uses the following Fibre Channel (FC) ports:

- F_Port - Fabric port that connects a host, HBA, or storage device to a switch in AG mode.
- N_Port - Node port that connects a switch in AG mode to the F_Port of the fabric switch.
- D_Port - Port configured in diagnostic mode so that various tests can run between it and connected D_Port on another switch or HBA across a link.

NOTE

Initiate the **portcfgpersistenable** command on all external or outward facing ports to ensure that these ports come back online after a switch reboot or power failure. For an embedded switch, execute this command through the chassis management console and not the switch CLI or the command may not persist. Refer to [“Persisting port online state”](#) on page 31 for more information.

Comparison of Access Gateway ports to standard switch ports

Access Gateway multiplexes host connections to the fabric. It presents an F_Port to the host and an N_Port to an Edge fabric switch. Using N_Port ID Virtualization (NPIV), AG allows multiple FC initiators to access the SAN on the same physical port. This reduces the hardware requirements and management overhead of hosts to the SAN connections.

A fabric switch presents F_Ports (or FL_Ports) and storage devices to the host and presents E_Ports, VE_Ports, or EX_Ports to other switches in the fabric. A fabric switch consumes SAN resources, such as domain IDs, and participates in fabric management and zoning distribution. A fabric switch requires more physical ports than AG to connect the same number of hosts.

1 Access Gateway port types

Figure 3 shows a comparison of the types of ports a switch in AG mode uses to the type of ports that a switch uses in standard mode.

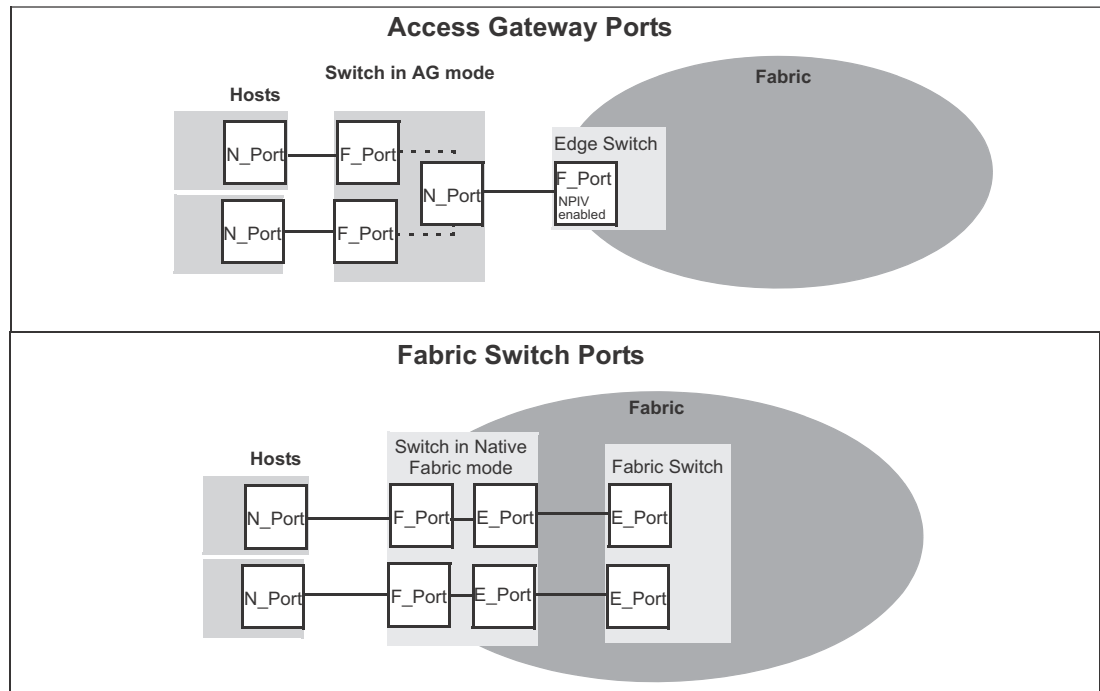

FIGURE 3 Port usage comparison

You can convert a Fibre Channel port into a D_Port on AG switch and a connected fabric switch, another AG switch (cascaded configuration), or an HBA to test the link between the ports. When you configure the ports on each end of the link as D_Ports, diagnostic tests automatically initiate on the link when the D_Ports go online. Results can be viewed using Fabric OS commands, such as **portDPortTest**, during or after testing. Once in D_Port mode, the port does not participate in fabric operations, login to a remote device, or run data traffic. Figure 4 on page 10 illustrates the supported D_Port configurations.

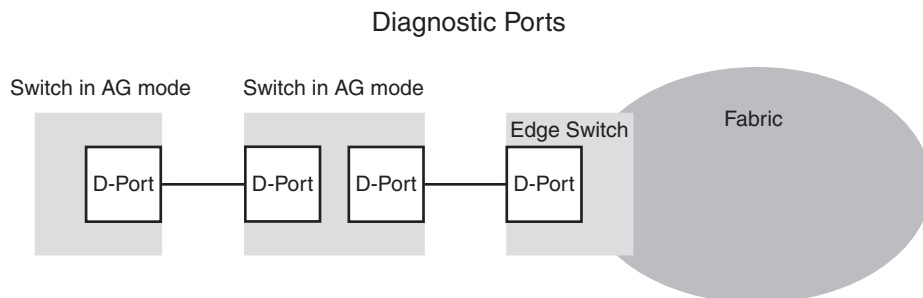

FIGURE 4 Diagnostic port configurations

Table 4 shows a comparison of port configurations between AG and a standard fabric switch.

TABLE 4 Port configurations

Port type	Available on Access Gateway?		Available on Fabric switch?	
F_Port	Yes	Connects hosts and targets to Access Gateway.	Yes	Connects devices, such as hosts, HBAs, and storage to the fabric.
N_Port	Yes	Connects Access Gateway to a fabric switch.	NA	N_Ports are not supported.
E_Port	NA	ISL is not supported. ¹	Yes	Connects the switch to other switches to form a fabric.
D_Port	Yes	Allows diagnostic testing across link to connected AG switch, fabric switch, or HBA.	Yes	Allows diagnostic testing across link to connected AG switch.

1. The switch is logically transparent to the fabric, therefore it does not participate in the SAN as a fabric switch.

Access Gateway hardware considerations

Hardware considerations for Access Gateway are as follows:

- Access Gateway is supported on the switch platforms and embedded switch platforms listed in [“Supported hardware and software”](#) on page xiv.
- Loop devices are not supported.
- Direct connections to SAN target devices are only supported if the AG-enabled module is connected to a fabric.

1 Access Gateway hardware considerations

Configuring Ports in Access Gateway Mode

- [Enabling and disabling Access Gateway mode](#) 13
- [Access Gateway mapping](#) 15
- [N_Port configurations](#) 30
- [D_Port support](#) 32

Enabling and disabling Access Gateway mode

Use the following steps to enable and disable Access Gateway mode. After you enable AG mode, some fabric information is erased, such as the zone and security databases. Enabling AG mode is disruptive because the switch is disabled and rebooted. For more information on the **ag** commands used in these steps, refer to the *Fabric OS Command Reference Manual*.

1. Connect to the switch and log in using an account assigned to the admin role.
2. Before enabling or disabling a switch to AG mode, save the current configuration file using the **configUpload** command in case you might need this configuration again.
3. Ensure that no zoning or Admin Domain (AD) transaction buffers are active. If any transaction buffer is active, enabling AG mode will fail with the error, “Failed to clear Zoning/Admin Domain configuration”.
4. Verify that the switch is set to Native mode.
 - a. Issue the **switchShow** command to verify the switch mode.
 - b. If the switch mode is anything other than 0, issue the **interopmode 0** command to set the switch to Native mode.

For more information on setting switches to Native mode, refer to the *Fabric OS Administrator’s Guide*.

5. Enter the **switchDisable** command.

```
switch:admin> switchdisable
```

This command disables all user ports on a switch. All Fibre Channel ports are taken offline. If the switch is part of a fabric, the remaining switches reconfigure. You must disable the switch before making configuration changes.

6. Enter the **ag --modeenable** command.

```
switch:admin> ag --modeenable
```

The switch automatically reboots and comes back online in AG mode using a factory default port mapping. For more information on AG default port mapping, see [Table 7](#) on page 17.

2 Enabling and disabling Access Gateway mode

7. Enter the **ag --modeshow** command to verify that AG mode is enabled.

```
switch:admin> ag --modeshow
Access Gateway mode is enabled.
```

You can display the port mappings and status of the host connections to the fabric on Access Gateway.

8. Enter the **ag --mapshow** command to display all the mapped ports.

The **ag --mapshow** command shows all enabled N_Ports, even if those N_Ports are not connected.

9. Enter the **switchShow** command to display the status and port state of all ports. Refer to the *Fabric OS Command Reference Manual* for examples of output. For a description of the port state, refer to [Table 5](#) on page 14.

When you disable AG mode, the switch automatically reboots and comes back online using the fabric switch configuration; the AG parameters, such as port mapping, and Failover and Failback, are automatically removed. When the switch reboots, it starts in Fabric OS Native mode. To rejoin the switch to the core fabric, refer to [“Rejoining Fabric OS switches to a fabric”](#) on page 79.

10. Enter the **switchDisable** command to disable the switch.

```
switch:admin> switchdisable
```

11. Enter the **ag** command with the **--modedisable** option to disable AG mode.

```
switch:admin> ag --modedisable
```

12. Enter the **ag --modeshow** command to verify that AG mode is disabled.

```
switch:admin> ag --modeshow
Access Gateway mode is NOT enabled
```

Port state description

[Table 5](#) describes the possible port states.

TABLE 5 Port state description

State	Description
No_Card	No interface card present
No_Module	No module (GBIC or other) present
Mod_Val	Module validation in process
Mod_Inv	Invalid module
No_Light	Module is not receiving light
No_Sync	Receiving light but out of sync
In_Sync	Receiving light and in sync
Laser_Flt	Module is signaling a laser fault
Port_Flt	Port marked faulty
Diag_Flt	Port failed diagnostics

TABLE 5 Port state description (Continued)

State	Description
Lock_Ref	Locking to the reference signal
Testing	Running diagnostics
Offline	Connection not established (only for virtual ports)
Online	Port is up and running

Access Gateway mapping

When operating in AG mode, you must specify pre-provisioned routes that AG will use to direct traffic from the devices (hosts or targets) on its F_Ports to the ports connected to the fabric using its N_Ports. This is unlike Native switch mode where the switch itself determines the best path between its F_Ports. This process of pre-provisioning routes in AG mode is called “mapping.”

During mapping, device World Wide Names (WWNs) or F_Ports are assigned to N_Ports and N_Port groups on the switch running in AG mode. Mapping ensures that a device logging in to the switch will always connect to the fabric through a specific N_Port or N_Port group. Two types of mapping are available:

- Port mapping
A specific F_Port is mapped to a specific N_Port. This ensures that all traffic from a specific F_Port always goes through the same N_Port. To map an F_Port to an N_Port group, simply map the port to an N_Port that belongs to that port group. All F_Ports mapped to that N_Port will be part of that N_Port group.
- Device mapping (optional)
A specific device WWN is mapped to N_Port groups (preferred method) or to specific N_Ports. Device mapping allows a virtual port to access its destination device regardless of the F_Port where the device resides. Device mapping also allows multiple virtual ports on a single physical machine to access multiple destinations residing in different fabrics.

Device mapping is optional and should be added on top of existing port maps. Port mapping must exist at all times.

Port mapping

F_Ports must be mapped to N_Ports before the F_Ports can come online. [Figure 5](#) on page 16 shows an example in which eight F_Ports are mapped evenly to four N_Ports on a switch in AG mode. The N_Ports connect to the same fabric through different Edge switches.

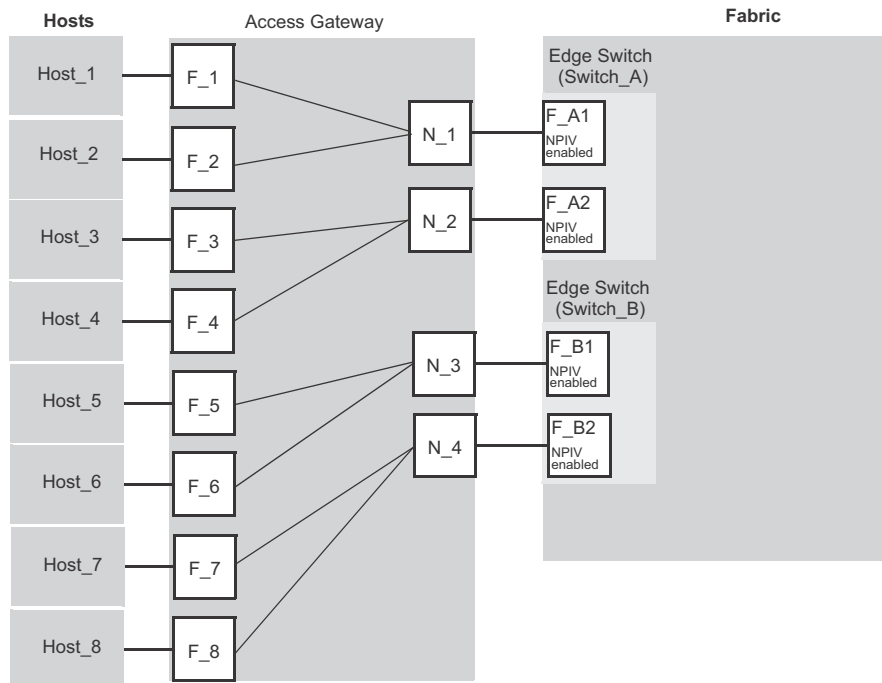

FIGURE 5 Port mapping example

[Table 6](#) provides a description of the port mapping in [Figure 5](#).

TABLE 6 Description of port mapping

Access Gateway		Fabric	
F_Port	N_Port	Edge switch	F_Port
F_1, F_2	N_1	Switch_A	F_A1
F_3, F_4	N_2	Switch_A	F_A2
F_5, F_6	N_3	Switch_B	F_B1
F_7, F_8	N_4	Switch_B	F_B2

Default port mapping

When you first enable a switch for AG mode, the F_Ports are mapped to a set of predefined N_Ports by default. [Table 7](#) on page 17 describes the default port mapping for all supported hardware platforms. By default, Failover and Failback policies are enabled on all N_Ports.

If you want to change the default mapping, refer to “[Adding F_Ports to an N_Port](#)” on page 20. Note that all F_Ports must be mapped to an N_Port before the F_Port can come online.

NOTE

All Ports On Demand (POD) licenses must be present to use Access Gateway on the Brocade 300, 5100, 6505, and 6510.

TABLE 7 Access Gateway default port mapping

Brocade Model	Total ports	F_Ports	N_Ports	Default port mapping
VA-40FC	40	0-31	32-39	0-3 mapped to 32 4-7 mapped to 33 8-11 mapped to 34 12-15 mapped to 35 16-19 mapped to 36 20-23 mapped to 37 24-27 mapped to 38 28-31 mapped to 39
NC-4380	24	1-16	0, 17-23	1, 2 mapped to 17 9, 10 mapped to 18 3, 4 mapped to 19 11, 12 mapped to 20 15, 16 mapped to 0 5, 6 mapped to 21 13, 14 mapped to 22 7, 8 mapped to 23
300	24	0-15	16 -23	0, 1 mapped to 16 2, 3 mapped to 17 4, 5 mapped to 18 6, 7 mapped to 19 8, 9 mapped to 20 10, 11 mapped to 21 12, 13 mapped to 22 14, 15 mapped to 23
5100	40	0-31	32-39	0, 1, 2, 3 mapped to 32 4, 5, 6, 7 mapped to 33 8, 9, 10, 11 mapped to 34 12, 13, 14, 15 mapped to 35 16, 17, 18, 19 mapped to 36 20, 21, 22, 23 mapped to 37 24, 25, 26, 27 mapped to 28 28, 29, 30, 31 mapped to 39
M5424	24	1-16	0, 17-23	1, 2 mapped to 17 3, 4 mapped to 18 5, 6 mapped to 19 7, 8 mapped to 20 9, 10 mapped to 21 11, 12 mapped to 22 13, 14 mapped to 23 15, 16 mapped to 0

2 Access Gateway mapping

TABLE 7 Access Gateway default port mapping (Continued)

Brocade Model	Total ports	F_Ports	N_Ports	Default port mapping
5430	16	1-10	0, 11-15	10 mapped to 0 1, 5 mapped to 11 2, 6 mapped to 12 3, 7 mapped to 13 4, 8 mapped to 14 9 mapped to 15
5431	16	4-15	0-3	4, 5, 12 mapped to 0 6, 7, 13 mapped to 1 8, 9, 14 mapped to 2 10, 11, 15 mapped to 3
5450	26	1-25 Not all ports may be present.	0, 19-25	1, 2, 17 mapped to 19 3, 4, 18 mapped to 20 5, 6 mapped to 21 7, 8 mapped to 22 9, 10 mapped to 23 11, 12 mapped to 24 13, 14 mapped to 25 15, 16 mapped to 0
5460	26	6-25	0-5	6, 16 mapped to 0 7, 17 mapped to 1 8, 12, 18, and 22 mapped to 2 9, 13, 19, and 23 mapped to 3 10, 14, 20, and 24 mapped to 4 11, 15, 21, and 25 mapped to 5
5470	20	1-14	0, 15-19	1, 2 mapped to 0 3, 4 mapped to 15 5, 6, 7 mapped to 16 8, 9 mapped to 17 10, 11 mapped to 18 12, 13, 14 mapped to 19
5480	24	1-16	0, 17-23	1, 2 mapped to 17 9, 10 mapped to 18 3, 4 mapped to 19 11, 12 mapped to 20 15, 16 mapped to 0 5, 6 mapped to 21 13, 14 mapped to 22 7, 8 mapped to 23
6505	24	0-15	16-23	0, 1 mapped to 16 2, 3 mapped to 17 4, 5 mapped to 18 6, 7 mapped to 19 8, 9 mapped to 20 10, 11 mapped to 21 12, 13 mapped to 22 14, 15 mapped to 23

TABLE 7 Access Gateway default port mapping (Continued)

Brocade Model	Total ports	F_Ports	N_Ports	Default port mapping
M6505	24	1-16	0, 17-31	1, 2 mapped to 17 3, 4 mapped to 18 5, 6 mapped to 19 7, 8 mapped to 20 9, 10 mapped to 21 11, 12 mapped to 22 13, 14 mapped to 23 14, 15 mapped to 0
6510	48	0-39	40-47	0-4 mapped to 40 5-9 mapped to 41 10-14 mapped to 42 15-19 mapped to 43 20-24 mapped to 44 25-29 mapped to 45 30-34 mapped to 46 35-39 mapped to 47
6547	48	1-28	0, 29-47	1, 21 mapped to 0 2, 22 mapped to 29 3, 23 mapped to 30 4, 24 mapped to 31 5, 25 mapped to 32 6, 26 mapped to 33 7, 27 mapped to 34 8, 28 mapped to 35 9 mapped to 36 10 mapped to 37 11 mapped to 38 12 mapped to 39 13 mapped to 40 14 mapped to 41 15 mapped to 42 16 mapped to 43 17 mapped to 44 18 mapped to 45 19 mapped to 46 20 mapped to 47

Considerations for initiator and target ports

The following connections are possible for the Fibre Channel Protocol (FCP) initiator (host) and target ports through AG:

- All F_Ports connect to all initiator ports.
- All F_Ports connect to all target ports.
- Some F_Ports connect to initiator ports and some F_Ports connect to target ports.

For the last case, communication between initiator and target ports is not supported if both are mapped to the same N_Port. Therefore, follow these recommendations for initiator and target port mapping:

- If connecting a host and target port to the same AG, you should map them to separate N_Ports and connect those N_Ports to the same fabric.
- Use separate port groups for initiator and target ports.
- When configuring secondary port mapping for failover and failback situations, make sure that initiator and target F_Ports will not fail over or fail back to the same N_Port.

Adding F_Ports to an N_Port

You can modify the default port mapping by adding F_Ports to an N_Port. Adding an F_Port to an N_Port routes that traffic to and from the fabric through the specified N_Port.

You can assign an F_Port to only one primary N_Port at a time. If the F_Port is already assigned to an N_Port, you must first remove it from the N_Port before you can add it to a different N_Port.

Use the following steps to add an F_Port to an N_Port.

1. Connect to the switch and log in using an account assigned to the admin role.
2. Enter the **ag** command with the **--mapadd n_portnumber f_port1;f_port2;...** option to add the list of F_Ports to the N_Port.

The F_Port list can contain multiple F_Port numbers separated by semicolons. In the following example, F_Ports 6 and 7 are mapped to N_Port 13.

```
switch:admin> ag --mapadd 13 "6;7"  
F-Port to N-Port mapping has been updated successfully
```

3. Enter the **ag --mapshow** command and specify the port number to display the list of mapped F_Ports. Verify that the added F_Ports appear in the list.

Removing F_Ports from an N_Port

1. Connect to the switch and log in using an account assigned to the admin role.
2. Remove any preferred secondary N_Port settings for the F_Port. Refer to [“Deleting F_Ports from a preferred secondary N_Port”](#) on page 53 for instructions.
3. Enter the **ag --mapdel N_Port** command with the **f_port1;f_port;...** option to remove F_Ports from an N_Port.

The F_Port list can contain multiple F_Port numbers separated by semicolons. In the following example, F_Ports 17 and 18 are removed from the N_Port where they were mapped.

```
switch:admin> ag --mapdel 17;18  
F-Port to N-Port mapping has been updated successfully
```

4. Enter the **switchShow** command to verify that the F_Port is free (unassigned).

In output for this command, the unassigned F_Port status “Disabled (No mapping for F_Port)” will display under the “Proto” column.

F_Port Static Mapping

The F_Port Static Mapping feature allows you to change mapping of an F_Port to a different N_Port using a single Fabric OS command (**staticadd** or **staticdel**), rather than using the **ag –mapdel** command to delete the existing N_Port port mapping to an F_Port, and then the **ag –mapadd** command to map a different N_Port to the F_Port. Using two commands can be slow and can cause some time-critical applications to malfunction.

Use the following steps to change F_Port to N_Port mapping.

1. Connect to the switch and log in using an account assigned to the admin role.
2. Enter the following command:

```
ag --staticadd "N-Port" "F-Port(s)"
```

Once F_Port Static Mapping is enabled, the F_Port and all attached devices log out of the previously mapped N_Port and log in to the new N_Port.

Use the following steps to remove the static mapping:

1. Connect to the switch and log in using an account assigned to the admin role.
2. Perform one of the following steps to remove mapping:
 - Map the F_Port to a different N_Port using the **ag –staticadd**.
 - Enter the following command to remove F_Port mapping entirely:

```
ag --staticdel "N-Port" "F-Port(s)"
```

Considerations for using F_Port Static Mapping with other AG features and policies

Consider the following when using F_Port Static Mapping with Access Gateway features and policies:

- F_Port Static Mapping functions with cascaded Access Gateway configurations.
- Failover, failback, and preferred secondary N_Port settings are disabled for F_Ports that are statically mapped.
- Statically mapped ports are blocked from using the Automatic Port Configuration (APC) and Advanced Device Security (ADS) policies. You cannot enable the APC policy until all static mappings are deleted using the **ag –staticdel** command.
- F_Port Static Mapping works with the Port Grouping (PG) policy with some modifications to policy behavior. If static mapping is applied to an F_Port already mapped to an N_Port, the F_Port will lose its mapping to the N_Port applied through the Port Grouping policy. Therefore, the F_Port will not have the failover, failback, or preferred N_Port settings that other F_Ports have when mapped to an N_Port in that port group. To remap to an N_Port with PG policy attributes, use the **ag –staticdel** command to remove the static mapping, and then remap to another N_Port using the **ag –mapadd** command.
- F_Port Static Mapping will not work with Device Load Balancing. Because F_Port Static Mapping forces the F_Port to stick with a specific N_Port, NPIV devices that log in to the F_Port cannot redistribute themselves among N_Ports in the port group.
- F_Port Static Mapping will not work with port trunking. If an F_Port is statically mapped to an N_Port and trunking is enabled, the F_Port goes offline. If port trunking is enabled for an F_Port already, you will be blocked from configuring static mapping for the F_Port.

Upgrade and downgrade considerations

- All static mappings will be maintained when upgrading to the latest Fabric OS version.
- When downgrading, you must remove all static mappings or downgrade will not be allowed.

Device mapping

Device mapping allows you to map individual N_Port ID Virtualization (NPIV) devices to N_Ports. By mapping device WWNs directly to an N_Port group (recommended) or specific N_Ports, traffic from the device will always go to the same N_Port or N_Port group, regardless of the F_Port where the device logs in. When the Port Grouping and Device Load Balancing policies are enabled for a port group, WWNs mapped to that port group are automatically balanced among the online N_Ports in that group (refer to [“Port Grouping policy modes”](#) on page 43).

NOTE

Port Grouping policy is not supported when both Automatic Login Balancing and Device Load Balancing are enabled.

Device mapping does not affect or replace the traditional port mapping. Device mapping is an optional mapping that will exist on top of existing port mapping. In general, mapping devices to N_Port groups is recommended over mapping devices to individual N_Ports within a port group. This ensures maximum device “up-time,” especially during failover conditions and system power up. This is especially true when a reasonably large number of devices must connect to the same fabric through a single port group.

The following aspects of device mapping are important to note:

- Logins from a device mapped to a specific N_Port or N_Port group (device mapping) always have priority over unmapped devices that log in to an F_Port that has been mapped to the same N_Port or N_Port group (port mapping).
- Current device routing (dynamic mapping) may turn out different than your intended mapping (static mapping), depending on which N_Ports are online and which policies are enabled (for example, Automatic Port Configuration, Device Load Balancing, Failover, or Failback). Therefore, it is recommended to map devices to N_Port groups instead of specific N_Ports within a port group when using device mapping.

NOTE

Automatic Port Configuration and Device Load Balancing cannot be enabled at the same time.

[Figure 6](#) illustrates an example of device mapping to port groups. In the example, WWNs 1, 2, and 3 can connect to any N_Port in Port Group 1 (PG1), while WWNs 4 and 5 can connect with any N_Port in Port Group 2 (PG2).

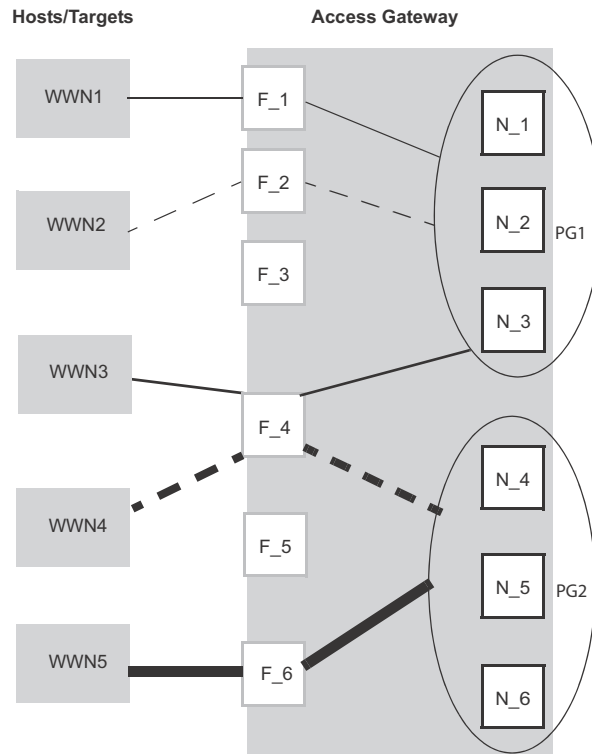

FIGURE 6 Example of device mapping to N_Port groups

Figure 7 shows an example of device mapping to specific N_Ports. Note that you can map one or multiple WWNs to one N_Port to allow multiple devices to log in through one N_Port.

2 Access Gateway mapping

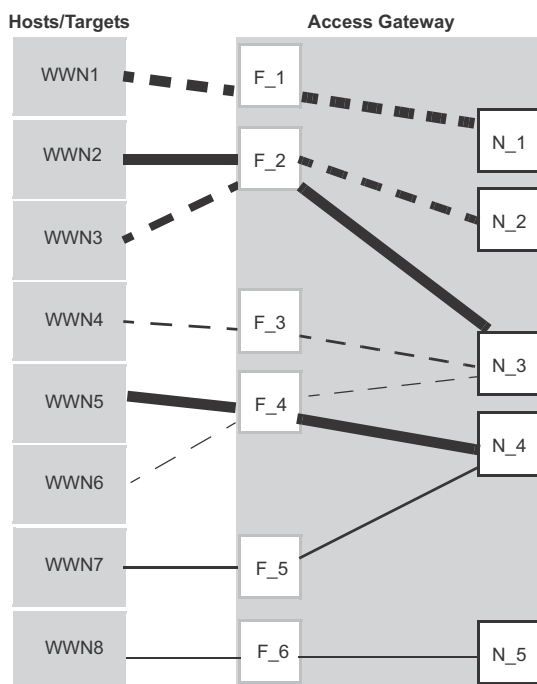

FIGURE 7 Example device mapping to an N_Port

Static versus dynamic mapping

Device mapping can be classified as either “static” or “dynamic” as follows:

- Device mapping to an N_Port and to an N_Port group are considered static. Static mappings persist across reboots and can be saved and restored with Fabric OS `configUpload` and `configDownload` commands.
- Automatic Device Load Balancing, if enabled, is considered dynamic. These mappings exist only while a device is logged in. Dynamic mappings cannot be saved or edited by the administrator and do not persist across reboots. Dynamic mapping shows the current mapping for devices as opposed to the original static mapping. If a device is mapped to an N_Port group, then all mapping is dynamic.

NOTE

Static and dynamic mapping only applies to NPIV devices and cannot redirect devices that are directly attached to Access Gateway because physically-attached devices use the port maps to connect to the fabric.

Device mapping to port groups (recommended)

Mapping NPIV devices to a port group is an ideal choice when a reasonably sized set of devices must connect to the same group of N_Ports, and you want the flexibility of moving the devices to any available F_Port. This type of mapping is recommended because the device will automatically connect to the least-loaded N_Port in the group if the N_Port to which the device is currently connected goes offline or is not yet online. For more information on port groups, refer to “[Port Grouping policy](#)” on page 41.

Use the following steps to map one or more devices to an N_Port group or remove device mapping from an N_Port group.

1. Connect to the switch and log in using an account assigned to the admin role.
2. To add one or multiple device WWNs to an N_Port group, enter the **ag --addwwnpgmapping Port_Group** command with the *[WWN];[WWN]* option.

All the listed device WWNs will use the least-loaded N_Port in the port group when they log in, unless a specific device mapping can be used instead. This command can only map devices currently connecting through NPIV.

The following example adds two devices to port group 3.

```
ag --addwwnpgmapping 3 "10:00:00:06:2b:0f:71:0c;10:00:00:05:1e:5e:2c:11"
```

3. To change all currently existing device mappings to a different port group, use the **--all** option instead of listing all the WWNs.

The following example changes all the currently mapped devices to use port group 3 instead of the current port group mappings.

```
ag --addwwnpgmapping 3 --all
```

4. To remove one or multiple devices to an N_Port group, enter the **ag --delwwnpgmapping Port_Group** command with the *[WWN];[WWN]* option.

All the listed devices will stop using the least-loaded N_Port in the group when they log in.

The following example removes mapping for two devices from port group 3.

```
ag --delwwnpgmapping 3 "10:00:00:06:2b:0f:71:0c;10:00:00:05:1e:5e:2c:11"
```

5. To remove all devices mapped to an N_Port group, enter the command with the **--all** option instead of listing all WWNs. All of the devices will cease automatic use of the least-loaded port in the port group when they log in. The **--all** option is a shortcut for specifying all of the devices that are already mapped with the **addwwnpgmapping** command.

The following example removes all devices mapped to port group 3.

```
ag --delwwnpgmapping 3 --all
```

6. Enter the **ag --wwnmapshow** command to display the list of WWNs mapped to port groups and verify that the correct devices have been mapped to the desired port group.

Device mapping to N_Ports

Use the following steps to add one or more devices to an N_Port to route all device traffic to and from the device through the specified N_Port. Also use these steps to remove device mapping to an N_Port.

1. Connect to the switch and log in using an account assigned to the admin role.
2. To add one or multiple devices to an N_Port, enter the **ag --addwwnmapping N_Port** command with the *[WWN];[WWN]* option. All the listed device WWNs will use the N_Port if it is available.

The following example adds two devices to N_Port 17.

```
ag --addwwnmapping 17 "10:00:00:06:2b:0f:71:0c;10:00:00:05:1e:5e:2c:11"
```

The **--all** option edits all the currently existing mappings. None of the **--all** options have any way to detect what devices are using the switch. This option edits the mappings that are in the list.

2 Access Gateway mapping

3. To change all current device mappings to a different N_Port, enter the **ag --addwwnmapping N_Port** command with the *--all* option.

The following command changes all the existing device mappings to use port 17.

```
ag --addwwnmapping 17 --all
```

4. To remove mapping for one or multiple devices from an N_Port, enter the **ag --delwwnmapping N_Port** command with the *[WWN];[WWN]* option. All the listed device WWNs will no longer try to use the N_Port unless a device logs in through an F_Port that is mapped to the N_Port.

The following example removes two devices from N_Port 17.

```
ag --delwwnmapping 17 "10:00:00:06:2b:0f:71:0c;10:00:00:05:1e:5e:2c:11"
```

5. To remove all devices currently mapped from an N_Port, enter the **ag --delwwnmapping N_Port** command with the *--all* option. All the listed devices will no longer try to use the N_Port unless a device logs in through an F_Port that is mapped to the N_Port. The *--all* option is a shortcut for specifying all of the devices that are already mapped with the **addwwnmapping** command.

The following command removes all devices currently mapped to port 17.

```
ag --delwwnmapping 17 --all
```

6. Enter the **ag --wwnmapshow** command to display the list of N_Ports mapped to WWNs and verify that the correct WWNs have been mapped or removed from the desired N_Ports.

Disabling device mapping

Use the following procedures to disable device mapping for all or only specific devices. These procedures are useful when you want to temporarily disable device mapping, and then enable this at a later time without reconfiguring your original mapping. To enable device mapping, refer to [“Enabling device mapping”](#) on page 26.

1. Connect to the switch and log in using an account assigned to the admin role.
2. Enter the **ag --wwnmappingdisable** command with the *[WWN]; [WWN]* option to disable mapping for specific WWNs. The device mappings will be ignored for all the listed device WWNs without removing the entry from the WWN mapping database.

The following example disables device mapping for two WWNs.

```
switch:admin> ag --wwnmappingdisable "10:00:00:06:2b:0f:71:0c;  
10:00:00:05:1e:5e:2c:11"
```

3. Enter the **ag --wwnmappingdisable** command with the *--all* option to disable mapping for all available WWNs. The *--all* option will not affect mappings made in the future. Disabled mappings can be modified without automatically enabling them.

The following example removes device mapping for all available WWNs.

```
switch:admin> ag --wwnmappingdisable --all
```

Enabling device mapping

Use the following steps to enable device mapping for all or specific devices that were previously disabled.

1. Connect to the switch and log in using an account assigned to the admin role.
2. Enter the **ag --wwnmappingenable** command with the *[WWN]; [WWN]* option to enable mapping for specific WWNs.

The following example enables two device WWNs.

```
switch:admin> ag --wwnmappingenable "10:00:00:06:2b:0f:71:0c;  
10:00:00:05:1e:5e:2c:11"
```

3. Enter the **ag --wwnmappingenable** command with the **--all** option to enable mapping for all currently available WWNs. The **--all** option will not affect mappings made in the future. Any mapping added for a new device (a device for which mapping is not disabled) will be enabled by default. Disabled mappings can be modified without automatically enabling them.

The following command enables all previously disabled device mappings.

```
switch:admin> ag --wwnmappingenable --all
```

Displaying device mapping information

The **ag --wwnmapshow** command displays static and dynamic mapping information about all device WWNs that have been mapped to N_Ports or N_Port groups. For each WWN, this command displays the following:

- WWN - Device WWNs that are mapped to N_Ports
- 1st N_Port - First or primary mapped N_Port (optional)
- 2nd N_Port - Secondary or failover N_Port (optional)
- PG_ID - Port Group ID where the device is mapped
- Current - The N_Port that the device is using (none displays if the device is not logged in)
- Enabled - Indicates whether device mapping is enabled or disabled

Note that new device mappings will only be enabled and display the next time the device logs in to the switch.

To display device mapping information, enter the **ag --wwnmapshow** command.

Pre-provisioning

You can use Fabric OS commands, Web Tools, and Fabric Manager to map devices that do not yet exist. This allows applicable management programs to push configuration changes without worrying about the order in which they are received. For example, if system administrators need to push a set of port group changes and a set of device mapping changes, they could push them in either order without error. This also applies to using Fabric OS commands for device mapping. You could also map several devices to a new port group and then create the group without error. You can also remove one device, and then remove another device without error.

VMware configuration considerations

Enabling device mapping for individual virtual machines (VMs) running on a VMware ESX server connected to an F_Port can redirect I/O traffic for these VMs, provided the server is configured to use Raw Device Mapped storage. All traffic will originate from a VM's WWN and will follow any mapping configured for the WWN. If anything interrupts the virtual port's connection for the VM, such as a failover port being used because a port goes offline, traffic will originate from the ESX server's base device port ID and not the VM's port ID. If there are any additional disruptions, the server will not switch back to the virtual port, and the VM's traffic will not follow the configured device mapping. Note that this can also occur when a VM first boots, prior to any failover.

When this behavior occurs, the VM's WWN will be properly logged in to the fabric. The WWN appears in the output of **ag -show** and **ag -wwnmapshow**, as well as on the switch. The output from the **portperfs** command displays all traffic on the port to which the ESX server port is mapped (base PID).

Configuring device mapping

To configure WWN mapping on VMware ESX systems, use the following steps.

1. Make sure that virtual world wide port names (VWWPN) of virtual machines (VMs) are mapped to the correct port group (or N_Port). Map all VWWPNs to N_Ports to avoid confusion.
2. Make sure all VWWPNs are mapped for LUN access for array-based targets.
3. Make sure to include all VWWPNs in the zone configuration.
4. Reboot the VM.
5. Zone the server's physical port to the storage device.
6. Check the traffic that originates from the virtual node PID (VN PID). If the configuration is correct, traffic will flow from the VN PID.

For additional information on using device mapping for connecting VMware systems, refer to the Technical Brief *How to Configure NPIV on VMware ESX Server 3.5*:

http://www.brocade.com/downloads/documents/brocade_vmware_technical_briefs/Brocade_NPIV_ESX3.5_WP.pdf.

Failover and failback considerations

When using device mapping with VMware, the base device initiates PLOGI and PRLI to the target, and then discovers the LUN. The virtual device also initiates a PLOGI and PRLI to the target, but LUN discovery does not occur. Therefore, when the device-mapped port is toggled and failover or failback takes place, traffic will resume from the base device. One of the following actions is recommended when using device mapping with VMware:

- Make sure targets can be reached by the base device so that I/Os can resume if the mapped device fails over and I/Os move over to the base PID.
- Reboot the server so that it initializes and uses configured device mapping.

Considerations for Access Gateway mapping

This section outlines considerations and limitations for Access Gateway mapping types.

Mapping priority

To avoid potential problems when both port and device mapping are implemented, AG uses the following priority system when verifying policies to select the N_Port where a fabric login (FLOGI) is routed. Access Gateway considers all available mappings in the following order until one can be used.

NOTE

Only NPIV devices can use device mapping and the automatic Device Load Balancing policy. Device Load Balancing policy is enabled per module rather than per port group.

1. Static device mapping to N_Port (if defined)
2. Device mapping to N_Port group (if defined)
For more information, refer to “[Port Grouping policy](#)” on page 41.
3. Automatic Device Load Balancing within a port group (if enabled)
For more information, refer to “[Port Grouping policy](#)” on page 41.
4. Port mapping to an N_Port
5. Port mapping to an N_Port in a port group (if defined)
For more information, refer to “[Port Grouping policy](#)” on page 41.

Device mapping considerations

Consider the following points when using device mapping:

- If the N_Port is disabled, all devices that are mapped to it will be disabled. Depending on the effective failover policy, the devices will be enabled on other N_Ports.
- Similar to port mappings, device mappings are affected by changes to underlying F_Ports. In other words, if an F_Port needs to be taken offline, both the physical device and all virtual nodes behind it will momentarily go offline.
- Once devices are mapped to an N_Port rather than an N_Port group, they cannot be automatically rebalanced to another N_Port if an additional N_Port comes online.
- There can be cases where two NPIV devices logging in through the same F_Port are mapped to two different N_Ports that are connected to two different fabrics. In this case, both NPIV devices may be allocated the same PID by their respective fabrics. Once Access Gateway detects this condition, it will disable that F_Port, and the event will be logged.

NOTE

Access Gateway algorithms reduce the chances of PID collisions, but they cannot be totally eliminated. In some cases, you may be able to configure your virtual or physical fabrics to further reduce PID collisions.

- Device mapping is not supported when firmware is downgraded to Fabric OS v6.3.x or earlier. You must delete device mappings before downgrading or disable Device Load Balancing.
- Static and dynamic device mapping are only supported on the edge module in a cascaded Access Gateway configuration.
- When mapping devices to a port group, make sure that all ports in the group have the same NPIV login limit. If some ports have a lower login limit than the other ports, and there are many logins to the group, some devices will repeatedly attempt to connect to the device with the lower limit (because it has the fewest logins) and fail to connect.

N_Port configurations

By default, on embedded switches, only the internal ports of Access Gateway are configured as F_Ports. All external ports are configured (locked) as N_Ports. On standalone switches with AG support, a preset number of ports are locked as N_Ports, and the rest of the ports operate as standard F_Ports. Although some ports are locked as N_Ports, these ports can be converted to F_Ports. For example, [Figure 8](#) on page 30 shows a host connected to external ports of an embedded switch with the switch in AG mode. To convert an N_Port to an F_Port, first remove all the F_Ports that are mapped to that N_Port, then unlock the port from N_Port state. Finally, define a map for the port. It is highly recommended that all F_Ports mapped to the N_Port first be remapped to other N_Ports before converting the N_Port to an F_Port. Also note that if the Automatic Port Configuration (APC) policy is enabled, the port conversion is done automatically and no user intervention is necessary. For more information on which ports are locked as N_Ports by default, see [Table 7](#) on page 17.

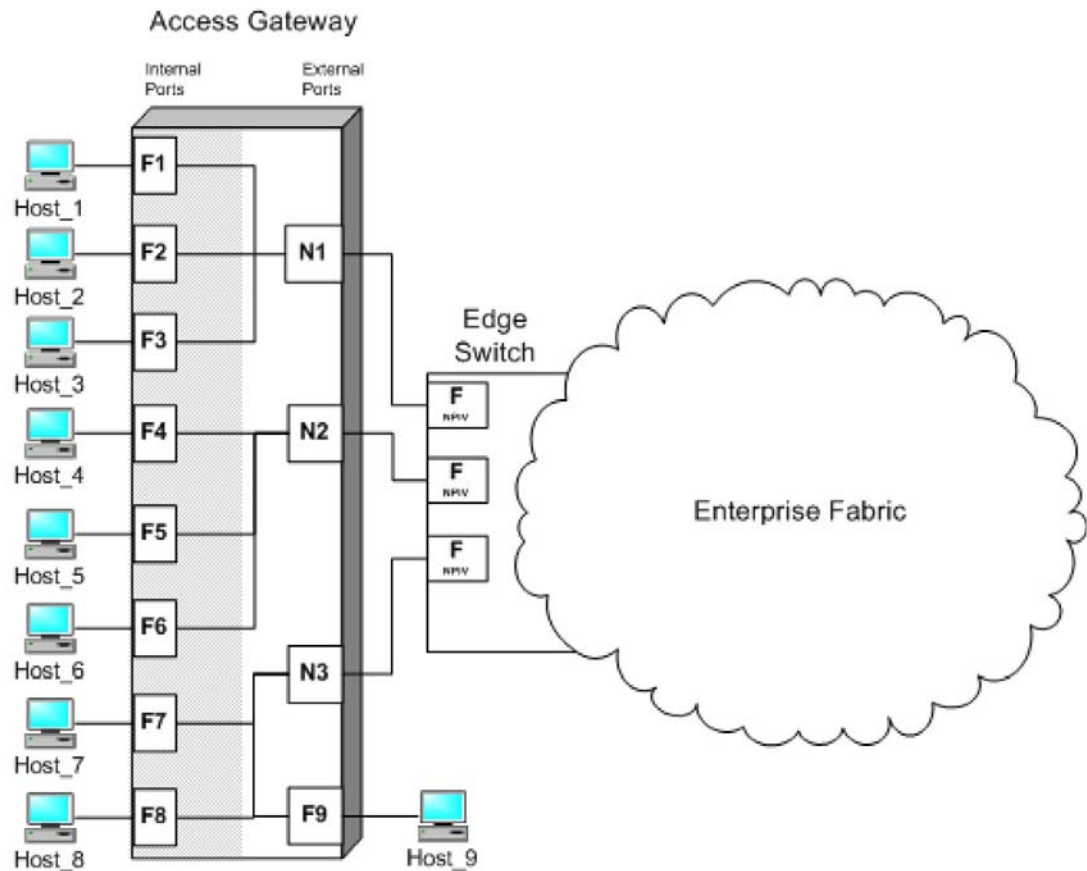

FIGURE 8 Example of adding an external F_Port (F9) on an embedded switch

NOTE

A switch in Access Gateway mode must have at least one port configured as an N_Port. Therefore, the maximum number of F_Ports that can be mapped to an N_Port is the number of ports on the switch minus one.

Displaying N_Port configurations

Use the following steps to determine which ports on a switch are locked as N_Ports.

1. Connect to the switch and log in using an account assigned to the admin role.
2. Enter the **portcfgnport** command. Command output will display “ON” for locked N_Ports.

Unlocking N_Ports

By default, on embedded switches, all external ports are configured in N_Port lock mode when you enable Access Gateway. Access Gateway connects only FCP initiators and targets to the fabric. It does not support other types of ports, such as ISL (interswitch link) ports.

By default, on fabric switches, the port types are not locked. Fabric OS Native mode dynamically assigns the port type based on the connected device: F_Ports and FL_Ports for hosts, HBAs, and storage devices; and E_Ports, EX_Ports, and VE_Ports for connections to other switches.

Unlocking the N_Port configuration automatically changes the port to an F_Port. When you unlock an N_Port, the F_Ports are automatically unmapped and disabled.

Following are procedures for unlocking N_Ports that are in locked mode.

1. Connect to the switch and log in using an account assigned to the admin role.
2. Enter the **portcfgnport** command to display which ports on the switch are locked as N_Ports. Command output will display “ON” for locked N_Ports.

NOTE

The **portcfgnport** command only works when the Port Grouping policy is enabled.

3. Enter the **portcfgnport** command and specify the port number and 0 (zero) to unlock N_Port mode.

```
switch:admin> portcfgnport 10 0
```

Alternatively, to lock a port in N_Port mode, enter the **portcfgnport** and specify the port number and 1.

```
switch:admin> portcfgnport 10 1
```

Persisting port online state

Initiate the **portcfgpersistenable** command on all external or outward facing ports to ensure that these ports come back online after a switch reboot or power failure. For an embedded switch, execute this command through the chassis management console and not the switch CLI or the command may not persist.

If the port is connected to another switch when this command is issued, the fabric may reconfigure. After the port is persistently enabled, devices connected to the port can again communicate with the fabric. Identify a single port to be configured by its port number or by its port index number. Port ranges are supported with index numbers or by specifying a slot or a slot range. Issue the **switchShow** command for a list of valid ports, slots, and port index numbers.

As an example, to persistently enable a port or range of ports, enter the following:

```
portcfgpersistenable [slot/]port1[-port2] [...]
```

D_Port support

The Diagnostic (D_Port) feature is supported on 16 Gbps ports only in the following configurations:

- AG switch connected to AG switch in cascaded configuration.
- AG switch connected to Brocade fabric switch.
- AG switch connected to a Brocade Host Bus Adapter (HBA).

You can convert a Fibre Channel port into a D_Port on an AG switch, Brocade HBA, fabric switch, or another AG switch (cascaded configuration) to test the link between the ports. When you configure the ports on each end of the link as a D_Port, diagnostic tests automatically initiate on the link when the D_Ports go online. Once in D_Port mode, the port does not participate in fabric operations, login to a remote device, or run data traffic. [Figure 4](#) on page 10 illustrates the supported D_Port configurations.

The AG switch does not support D_Port dynamic mode at this time. In other words, if the port on the connected switch or adapter is configured as a D_Port, the AG port is not automatically enabled as a D_Port. D_Port must be configured on the AG port in static mode. Once enabled, you can stop tests, restart tests, and control other test functions from the AG switch, connected switch, or connected HBA.

NOTE

N_Port to F_Port mappings must be removed from an AG port F_Port before configuring it as a D_Port. Refer to [“Saving port mappings”](#) on page 33.

Results from D_Port testing can be viewed using Fabric OS commands, such as **portDPortTest - - show**, during or after testing. Either the adapter, fabric switch, or AG switch will be the initiator and the other will be the responder. You can view detailed results from the initiator.

The following tests automatically run on the link between configured D_Ports:

- Electrical loopback in SFP.
- Optical loopback in SFP.
- End-to-end loopback
- Link traffic test to test frame flow to ASIC or firmware.
- Link latency and distance measurement.

For details on configuring D_Ports, using D_Ports, and D_Port limitations and considerations, refer to the *Fabric OS Troubleshooting and Diagnostics Guide*. For details on D_Port-related commands refer to the *Fabric OS Command Reference*.

Limitations and considerations

Following are specific limitations and considerations for using D_Ports in AG switch configurations. For a complete list of D_Port limitations and considerations, refer to the *Fabric OS Troubleshooting and Diagnostics Guide*.

- D-Port must be configured on the AG, fabric switch, cascaded AG switch, or HBA before enabling D-ports on both sides of the link. Otherwise the port will be persistently disabled.
- After configuring D_Port for an AG switch port, mapping will not be retained. This includes F_Port to N_Port, static, preferred, and device (WWN) mapping. Therefore all mapping has to be manually removed on the Access Gateway port before configuring the port as a D_Port.

Saving port mappings

Before configuring D_Ports, you must remove all mappings between the subject ports and device as they will not be retained. This includes port (N_Port to F_Port), device (WWN), static, and dynamic mapping. You can save N_Port mappings using Fabric OS commands. Once you save the mappings, you can display them so that you can manually reconfigure them after the D_Port is disabled. A command is also available to delete saved N_Port mappings. The following are available backup mapping commands. For more details, refer to the *Fabric OS Command Reference*.

- To save configured N_Port mappings, enter the following command:

```
ag --backupmappingsave N_Port
```

- To display saved N__Port mappings so that you can reconfigure them on the switch, enter the following command:

```
ag --backupmappingshow N_Port
```

Following is an example of command output:

```
sw0:root>ag --backupmappingshow 44
Configured static and preferred mappings have been saved for the N_port
successfully
```

N_Port	44
Backed-up Configured F_Ports	20:21:22
Backed-up Static F_Ports	23:24
Backed-up Preferred F_Ports	26:27:28:29

- To delete configured N_Port mappings, enter the following command:

```
ag --backupmappingdel N_Port
```

2 D_Port support

Managing Policies and Features in Access Gateway Mode

• Access Gateway policies overview	35
• Advanced Device Security policy	36
• Automatic Port Configuration policy	39
• Port Grouping policy	41
• Device Load Balancing policy	47
• Persistent ALPA policy	48
• Failover policy	50
• Failback policy	55
• Trunking in Access Gateway mode	58
• Adaptive Networking on Access Gateway	65
• Per-Port NPIV login limit	67
• Performance Monitoring	68
• Considerations for the Brocade 6505 and 6510	71

Access Gateway policies overview

This chapter provides detailed information on all Access Gateway policies. These policies can be used to control various advanced features, such as failover, failback, and trunking, when used in Access Gateway mode.

Displaying current policies

You can run the following command to display policies that are currently enabled or disabled on a switch.

1. Connect to the switch and log in using an account assigned to the admin role.
2. Enter the **ag --policyshow** command.

Access Gateway policy enforcement matrix

Table 8 shows which policies can be enabled at the same time. For example, in the Auto Port Configuration policy row, only N_Port Trunking and Advanced Device Security can be enabled with this policy.

TABLE 8 Policy enforcement matrix

Policies	Auto Port Configuration	N_Port Grouping	N_Port Trunking	Advanced Device Security
Auto Port Configuration	N/A	No	Yes	Yes
N_Port Grouping	Mutually exclusive	N/A	Yes	Yes
N_Port Trunking	Yes	Yes	N/A	Yes
Advanced Device Security ¹	Yes	Yes	Yes	N/A
Device Load Balancing ²	No	Yes	Yes	Yes

1. The ADS policy is not supported when using device mapping.
2. Device Load Balancing and Automatic Login Balancing cannot be enabled for the same port group.

Advanced Device Security policy

Advanced Device Security (ADS) is a security policy that restricts access to the fabric at the AG level to a set of authorized devices. Unauthorized access is rejected and the system logs a RASLOG message. You can configure the list of allowed devices for each F_Port by specifying their Port WWN (PWWN). The ADS policy secures virtual and physical connections to the SAN.

How the ADS policy works

When you enable the ADS policy, it applies to all F_Ports on the AG-enabled module. By default, all devices have access to the fabric on all ports. You can restrict the fabric connectivity to a particular set of devices where AG maintains a per-port allow list for the set of devices whose PWWN you define to log in through an F_Port. You can view the devices with active connections to an F_Port using the **ag -show** command.

NOTE

The **ag --show** command only displays F_Ports on Core AGs, such as the AGs that are directly connected to fabric. Use the **agshow --name** command on the fabric switch to display the F_Ports of both the Core and Edge AGs.

Alternatively, the security policy can be established in the Enterprise fabric using the Device Connection Control (DCC) policy. For information on configuring the DCC policy, see [“Enabling the DCC policy on a trunk”](#) on page 60. The DCC policy in the Enterprise fabric takes precedence over the ADS policy. It is generally recommended to implement the security policy in the AG module rather than in the main fabric, especially if the Failover and Failback policies are enabled.

Enabling and disabling the ADS policy

By default, the ADS policy is disabled. When you manually disable the ADS policy, all of the allow lists (global and per-port) are cleared. Before disabling the ADS policy, you should save the configuration using the **configUpload** command in case you need this configuration again.

1. Connect to the switch and log in using an account assigned to the admin role.
2. Enter the **ag --policyenable ads** command to enable the ADS policy.

```
switch:admin> ag --policyenable ads
The policy ADS is enabled
```

3. Enter the **ag --policydisable ads** command to disable the ADS policy.

```
switch:admin> ag --policydisable ads
The policy ADS is disabled
```

NOTE

Use the **ag --policyshow** command to determine the current status of the ADS policy.

Allow lists

You can determine which devices are allowed to log in on a per-F_Port basis by specifying lists of F_Ports and device WWNs in the **ag --adsset** command. The ADS policy must be enabled for this command to succeed.

ag --adsset "F_Port [;F_Port2;...]" "WWN [;WWN2;...]"

Lists must be enclosed in quotation marks. List members must be separated by semicolons. The maximum number of entries in the allowed device list is twice the per-port maximum login count.

Use an asterisk (*) instead of port numbers in the F_Port list to add the specified WWNs to all the F_Ports allow lists. Use an asterisk (*) instead of WWNs to indicate access to all devices from the specified F_Port list. A blank WWN list ("") indicates no access.

NOTE

Use an asterisk enclosed in quotation marks ("*") to set the allow list to "all access"; use a pair of double quotation marks ("") to set the allow list to "no access".

Note the following characteristics of the allow list:

- The maximum device entries allowed in the allow list is twice the per-port maximum login count.
- Each port can be configured to "not allow any device" or "to allow all the devices" to log in.
- If the ADS policy is enabled, by default, every port is configured to allow all devices to log in.
- The same allow list can be specified for more than one F_Port.

Setting the list of devices allowed to log in

1. Connect to the switch and log in using an account assigned to the admin role.
2. Enter the **ag --adsset** command with the appropriate options to set the list of devices allowed to log in to specific ports. In the following example, ports 1, 10, and, 13 are set to "all access."

```
switch:admin> ag --adsset "1;10;13" "*"
WWN list set successfully as the Allow Lists of the F_Port[s]
```

Setting the list of devices not allowed to log in

1. Connect to the switch and log in using an account assigned to the admin role.
2. Enter the **ag --adsset** command with the appropriate options to set the list of devices not allowed to log in to specific ports. In the following example, ports 11 and 12 are set to “no access.”

```
switch:admin > ag --adsset "11;12" ""  
WWN list set successfully as the Allow Lists of the F_Port[s]
```

Removing devices from the list of allowed devices

Remove specified WWNs from the list of devices allowed to log in to the specified F_Ports using the **ag --adsdel** command.

ag-adsdel “F_Port [;F_Port2;...]” “WWN [;WWN2;...]”

For more details on this command and its operands, refer to the *Fabric OS Command Reference Manual*.

Lists must be enclosed in quotation marks. List members must be separated by semicolons. Replace the F_Port list with an asterisk (*) to remove the specified WWNs from all the F_Ports allow lists. The ADS policy must be enabled for this command to succeed.

1. Connect to the switch and log in using an account assigned to the admin role.
2. Enter the **ag --adsdel** command to remove one or more devices from the list of allowed devices.

In the following example, two devices are removed from the list of allowed devices (ports 3 and 9).

```
switch:admin> ag --adsdel "3;9"  
"22:03:08:00:88:35:a0:12;22:00:00:e0:8b:88:01:8b"  
WWNs removed successfully from Allow Lists of the F_Port[s]Viewing F_Ports  
allowed to login
```

Adding new devices to the list of allowed devices

Add specified WWNs to the list of devices allowed to log in to the specified F_Ports using the **ag --adsadd** command.

ag-adsadd “F_Port [;F_Port2;...]” “WWN [;WWN2;...]”

For more details on this command and its operands, refer to the *Fabric OS Command Reference Manual*.

Lists must be enclosed in quotation marks. List members must be separated by semicolons. Replace the F_Port list with an asterisk (*) to add the specified WWNs to all the F_Ports allow lists. The ADS policy must be enabled for this command to succeed.

1. Connect to the switch and log in using an account assigned to the admin role.
2. Enter the **ag --adsadd** command with the appropriate options to add one or more new devices to the list of allowed devices.

In the following example, two devices are added to the list of allowed devices (for ports 3 and 9).

```
switch:admin> ag --adsadd "3;9"  
"20:03:08:00:88:35:a0:12;21:00:00:e0:8b:88:01:8b"  
WWNs added successfully to Allow Lists of the F_Port[s]
```

Displaying the list of allowed devices on the switch

1. Connect to the switch and log in using an account assigned to the admin role.
2. Enter the `ag --adsshow` command.

For each F_Port, command output will show access for all devices, a list of device WWNs, or no access. For more details on this command and its output, refer to the *Fabric OS Command Reference Manual*.

ADS policy considerations

The following are considerations for setting the ADS policy:

- In cascading configurations, you should set the ADS policy on the AG module that directly connects to the servers.
- The ADS policy can be enabled or disabled independent of the status of other AG policies.
- The ADS policy is not supported with device mapping.

Upgrade and downgrade considerations for the ADS policy

Downgrading to Fabric OS v6.4.0 or earlier is supported.

Downgrading from Fabric OS v7.1.0 to v6.4.0 or upgrading from Fabric OS v6.4.0 to v7.1.0 will not change the ADS policy settings.

Automatic Port Configuration policy

The Automatic Port Configuration (APC) provides the ability to automatically discover port types (host, target, or fabric) and dynamically update the port maps when a change in port-type connection is detected. This policy is intended for a fully hands-off operation of Access Gateway. APC dynamically maps F_Ports across available N_Ports so they are evenly distributed.

How the APC policy works

When the APC policy is enabled and a port on AG is connected to a Fabric switch, AG configures the port as an N_Port. If a host is connected to a port on AG, then AG configures the port as an F_Port and automatically maps it to an existing N_Port with the least number of F_Ports mapped to it. When the APC policy is enabled, it applies to all ports on the switch.

Enabling and disabling the APC policy

Use the following steps to enable and disable Automatic Port Configuration policy. This policy is disabled by default in Access Gateway.

Enabling the APC policy

1. Connect to the switch and log in using an account assigned to the admin role.
2. Enter the **switchDisable** command to ensure that the switch is disabled.
3. Enter the **configUpload** command to save the switch's current configuration.
4. Enter the **ag --policydisable pg** command to disable the Port Grouping (PG) policy.
5. Enter the **ag --policyenable auto** command to enable the APC policy.
6. At the command prompt, type **Y** to enable the policy.

The switch is ready; a reboot is not required.

Disabling the APC policy

1. Connect to the switch and log in using an account assigned to the admin role.
2. Enter the **switchDisable** command to ensure that the switch is disabled.
3. Enter the **configUpload** command to save the switch's current configuration.
4. Enter the **ag --policyDisable auto** command to disable the APC policy.
5. At the command prompt, type **Y** to disable the policy.
6. Enter the **switchEnable** command to enable the switch.

APC policy considerations

Following are the considerations for the Automatic Port Configuration (APC) policy:

- The APC and the PG policies cannot be enabled at the same time. You can still benefit from the automatic port mapping feature of the APC policy when the Port Grouping policy is enabled by enabling the auto distribution feature for each port group.
- You cannot manually configure port mapping when the APC policy is enabled.
- The APC policy applies to all ports on the switch. Enabling the APC policy is disruptive and erases all existing port mappings. Therefore, before enabling the APC policy, you should disable the AG module. When you disable the APC policy, the N_Port configuration and the port mapping revert back to the default factory configurations for that platform. It is recommended that before you either disable or enable APC policy, you save the current configuration file using the **configUpload** command in case you need this configuration again.

Upgrade and downgrade considerations for the APC policy

- You can downgrade to a Fabric OS level that supports the APC policy. You can upgrade from Fabric OS v6.4.0 to Fabric OS v7.1.0, and the policy that was enabled in Fabric OS v6.4.0 will be maintained. Upgrade to Fabric OS v7.1.0 from Fabric OS releases prior to v6.4.0 is not supported.

Port Grouping policy

Use the Port Grouping (PG) policy to partition the fabric, host, or target ports within an AG-enabled module into independently operated groups. Use the PG policy in the following situations:

- When connecting the AG module to multiple physical or virtual fabrics.
- When you want to isolate specific hosts to specific fabric ports for performance, security, or other reasons.

How port groups work

Create port groups using the `ag --pgcreate` command. This command groups N_Ports together as “port groups.” By default, any F_Ports mapped to the N_Ports belonging to a port group will become members of that port group. Port grouping fundamentally restricts failover of F_Ports to the N_Ports that belong to that group. For this reason, an N_Port cannot be member of two port groups. The default PGO group contains all N_Ports that do not belong to any other port groups.

Figure 9 shows that if you have created port groups and then an N_Port goes offline, the F_Ports being routed through that port will fail over to any of the N_Ports that are part of that port group and are currently online. For example, if N_Port 4 goes offline, then F_Ports 7 and 8 are routed through to N_Port 3 as long as N_Port 3 is online because both N_Ports 3 and 4 belong to the same port group, PG2. If no active N_Ports are available, the F_Ports are disabled. The F_Ports belonging to a port group do not fail over to N_Ports belonging to another port group.

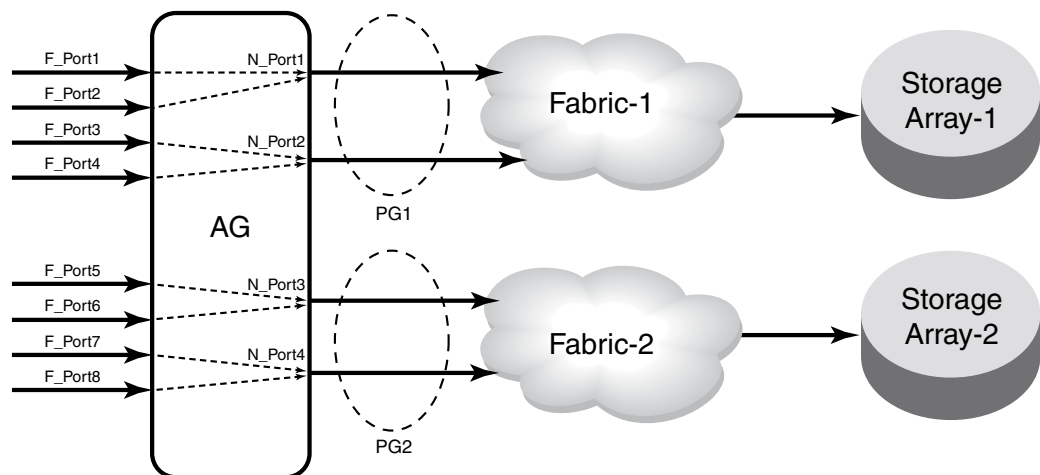

FIGURE 9 Port grouping behavior

When a dual redundant fabric configuration is used, F_Ports connected to a switch in AG mode can access the same target devices from both of the fabrics. In this case, you must group the N_Ports connected to the redundant fabric into a single port group. It is recommended to have paths fail over to the redundant fabric when the primary fabric goes down. Refer to Figure 10.

3 Port Grouping policy

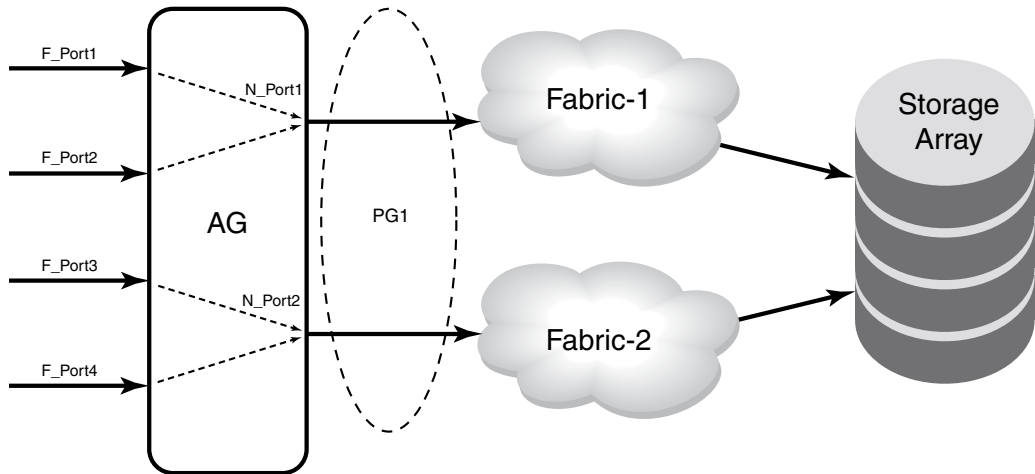

FIGURE 10 Port group 1 (PG1) setup

Adding an N_Port to a port group

1. Connect to the switch and log in using an account assigned to the admin role.
2. Enter the **ag --pgadd** command with the appropriate options to add an N_Port to a specific port group. In the following example, N_Port 14 is added to port group 3.

Note that if you add more than one N_Port, you must separate them with a semicolon.

```
switch:admin> ag --pgadd 3 14
N_Port[s] are added to the port group 3
```

Deleting an N_Port from a port group

Before deleting an N_Port, all F_Ports mapped to the N_Port should be remapped before the N_Port is deleted from a port group.

1. Connect to the switch and log in using an account assigned to the admin role.
2. Enter the **ag --pgdel** command with the appropriate options to delete an N_Port from a specific port group. In the following example, N_Port 13 is removed from port group 3.

```
switch:admin> ag --pgdel 3 13
N_Port[s] are deleted from port group 3
```

3. Enter the **ag --pgshow** command to verify the N_Port was deleted from the specified port group.

Removing a port group

1. Connect to the switch and log in using an account assigned to the admin role.
2. Enter the **ag --pgremove** command with the appropriate options to remove a port group. In the following example, port group 3 is removed.

```
switch:admin> ag --pgremove 3
```

Renaming a port group

1. Connect to the switch and log in using an account assigned to the admin role.
2. Enter the **ag --pgrename** command with the appropriate options to rename a port group. In the following example, port group 2 is renamed to MyEvenFabric.

```
switch:admin> ag --pgrename 2 MyEvenFabric
Port Group 2 has been renamed as MyEvenFabric successfully
```

Disabling the Port Grouping policy

The Port Grouping (PG) policy is enabled by default for Access Gateway. To disable this policy, use the following steps.

1. Connect to the switch and log in using an account assigned to the admin role.
2. Enter the **ag --policydisable pg** command to disable the Port Grouping policy.

Port Grouping policy modes

You can enable and disable the Automatic Login Balancing and Managed Fabric Name Monitoring (MFNM) Port Grouping policy modes when you create port groups using the **pgcreate** command. Alternately, you can enable these modes using the **ag -pgsetmodes** command.

Automatic Login Balancing mode

If Automatic Login Balancing mode is enabled for a port group and an F_Port goes offline, logins in the port group are redistributed among the remaining F_Ports. Similarly, if an N_Port comes online, port logins in the port group are redistributed to maintain a balanced N_Port-to-F_Port ratio.

Consider the following notes about Automatic Login Balancing mode:

- Automatic Login Balancing mode is disruptive. However, you can minimize disruption by disabling or enabling rebalancing of F_Ports on F_Port offline events or N_Port online events. Refer to [“Rebalancing F_Ports”](#) on page 44.
- You must explicitly enable Automatic Login Balancing on a port group.
- If an N_Port is deleted from a port group enabled for Automatic Login Balancing mode, the F_Ports mapped to that N_Port stay with the port group as long as there are other N_Ports in the group. Only the specified N_Port is removed from the port group. This is because the F_Ports are logically associated with the port groups that are enabled for Automatic Login Balancing mode. This is not the case for port groups not enabled for Automatic Login Balancing mode. When you delete an N_Port from one of these port groups, the F_Ports that are mapped to the N_Port move to PGO along with the N_Port. This is because the F_Ports are logically associated with the N_Ports in port groups not enabled for Automatic Login Balancing mode.

Managed Fabric Name Monitoring mode

When enabled, Managed Fabric Name Monitoring (MFNM) mode queries the fabric name at a specific time period. If it detects an inconsistency, for example all the N_Ports within a port group are not physically connected to the same physical or virtual fabric, it generates a RASLOG message. In “default” mode, a message is logged into RASLOG. In “managed” mode, automatic failover is disabled for all N_Ports within the N_Port group, and a message is logged into RASLOG about multiple fabrics.

Enable or disable MFNM mode on a port group using the steps under “[Enabling MFNM mode](#)” on page 45 and “[Disabling MFNM mode](#)” on page 45. In both default and managed mode, the system queries the fabric name once every 120 seconds. You can configure the monitoring timeout value to something other than 120 seconds using the steps under “[Setting the current MFNM mode timeout value](#)” on page 46.

Creating a port group and enabling Automatic Login Balancing mode

1. Connect to the switch and log in using an account assigned to the admin role.
2. Enter the **ag --pgcreate** command with the appropriate options to create a port group. In the following example, a port group named “FirstFabric” is created that includes N_Ports 1 and 3 and has Automatic Login Balancing (lb) enabled.

```
switch:admin> ag --pgcreate 3 "1;3" -n FirstFabric1 -m "lb"  
Port Group 3 created successfully
```

3. Enter the **ag --pgshow** command to verify the port group was created. A table containing a port group with ID 3 and ports 1 and 3 should display.

Rebalancing F_Ports

To minimize disruption that could occur once F_Ports go offline or when additional N_Ports are brought online, you can modify the default behavior of Automatic Login Balancing mode by disabling or enabling rebalancing of F_Ports when F_Port offline or N_Port online events occur.

1. Connect to the switch and log in using an account assigned to the admin role.
2. Enter the **agautomapbalance --enable** command with the appropriate options to enable automatic login redistribution of F_Ports. In the following example, rebalancing of F_Ports in port group 1 in Access Gateway is enabled when an F_Port online event occurs.

```
switch:admin> agautomapbalance --enable -fport -pg 1
```

3. Enter the **agautomapbalance --disable -all** command with the appropriate options to disable automatic login distribution of N_Ports for all port groups in the Access Gateway when an N_Port online event occurs.

```
switch:admin> agautomapbalance --disable -nport -all
```

4. Enter the **agautomapbalance --disable -all** command with the appropriate options to disable automatic login distribution of F_Ports for all port groups in the Access Gateway when an F_Port online event occurs.

```
switch:admin> agautomapbalance --disable -fport -all
```

5. Enter the **agautomapbalance --show** command to display the automatic login redistribution settings for port groups. In the following example, there are two port groups, 0 and 1.

```
switch:admin> agautomapbalance --show

AG Policy: pg
-----
PG_ID LB mode nport fport
-----
0 Enabled      Enabled   Disabled
1 Disabled     -        -
```

This command also displays the automatic login redistribution settings for N_Ports and F_Ports. For more details on this command and its output, refer to the *Fabric OS Command Reference Manual*.

Considerations when disabling Automatic Login Balancing mode

Consider the following when disabling Automatic Login Balancing mode:

- Be aware that modifying Automatic Login Balancing mode default settings using the **agautomapbalance** command may yield uneven distribution of F_Ports to N_Ports. In such cases, you might consider a manual login distribution that forces a rebalancing of F_Ports to N_Ports.
- To control automatic rebalancing to avoid disruptions when the Port Grouping policy is enabled, refer to [“Rebalancing F_Ports”](#) on page 44.

Enabling MFNM mode

1. Connect to the switch and log in using an account assigned to the admin role.
2. Enter the **ag --pgsetmodes** command with the appropriate options to enable MFNM mode. This command changes the monitoring mode from “default” to “managed.” In the following example, MFNM mode is enabled for port group 3.

```
switch:admin> ag --pgsetmodes 3 "mfnm"
Managed Fabric Name Monitoring mode has been enabled for Port Group 3
```

Disabling MFNM mode

1. Connect to the switch and log in using an account assigned to the admin role.
2. Enter the **ag --pgdelmodes** command with the appropriate options to disable MFNM mode. In the following example, MFNM mode is disabled for port group 3.

```
switch:admin> ag --pgdelmodes 3 "mfnm"
Managed Fabric Name Monitoring mode has been disabled for Port Group 3
```

3. Enter the **ag --pgshow** command to display the port group configuration. If disabled, “mfnm” should not display under PG_Mode for port 3.

For more details on this command and its operands, refer to the *Fabric OS Command Reference Manual*.

Displaying the current MFNM mode timeout value

1. Connect to the switch and log in using an account assigned to the admin role.
2. Enter the **ag --pgfnmtov** command to display the current MFNM timeout value.

```
switch:admin> ag --pgfnmtov  
  
Fabric Name Monitoring TOV: 120 seconds
```

Setting the current MFNM mode timeout value

1. Connect to the switch and log in using an account assigned to the admin role.
2. Enter the **ag --pgfnmtov** command, followed by a value in seconds.

```
switch:admin> ag --pgfnmtov 100  
  
This sets the timeout value to 100 seconds.
```

Port Grouping policy considerations

Following are the considerations for the Port Grouping policy:

- A port cannot be a member of more than one port group.
- The PG policy is enabled by default in Fabric OS v6.0 and later. A default port group “0” (PGO) is created, which contains all ports on the AG.
- APC policy and PG policy are mutually exclusive. You cannot enable these policies at the same time.
- If an N_Port is added to a port group or deleted from a port group and Automatic Login Balancing mode is enabled or disabled for the port group, the N_Port maintains its original failover or failback setting. If an N_Port is deleted from a port group, it automatically gets added to port group 0.
- When specifying a preferred secondary N_Port for a port group, the N_Port must be from the same group. If you specify an N_Port as a preferred secondary N_Port and it already belongs to another port group, the operation fails. Therefore, it is recommended to form groups before defining the preferred secondary path.
- If the PG policy is disabled while a switch in AG mode is online, all the defined port groups are deleted, but the port mapping remains unchanged. Before disabling the PG policy, you should save the configuration using the **configUpload** command in case you might need this configuration again.
- If N_Ports connected to unrelated fabrics are grouped together, N_Port failover within a port group can cause the F_Ports to connect to a different fabric. The F_Ports may lose connectivity to the targets to which they were connected before the failover, thus causing I/O disruption, as shown in [Figure 10](#) on page 42. Ensure that the port group mode is set to MFNM mode (refer to [“Enabling MFNM mode”](#) on page 45). This monitors the port group to detect connection to multiple fabrics and disables failover of the N-ports in the port group. For more information on MFNM, refer to [“Managed Fabric Name Monitoring mode”](#) on page 44.

Upgrade and downgrade considerations for the Port Grouping policy

Downgrading to Fabric OS v6.4.0 or earlier is supported.

Note the following considerations when upgrading to Fabric OS 7.1.0:

- When upgrading to Fabric OS v7.1.0 from v6.4.0, the PG policy that was enforced in Fabric OS v6.4.0 continues to be enforced in Fabric OS v7.1.0 and the port groups are retained. You should save the configuration file using the **configUpload** command in case you might need this configuration again.
- Upgrade to Fabric OS v7.1.0 from Fabric OS prior to v6.4.0 is not supported.

Device Load Balancing policy

When the Device Load Balancing policy is enabled, devices mapped to a port group always log in to the least-loaded N_Port in that port group. This helps to distribute the login load on each of the N_Ports. This policy is intended for use in conjunction with device mapping. It provides an automatic approach to mapping devices to the least-loaded N_Port within an N_Port group. To effectively use this policy, it is recommended that you map devices to desired N_Port groups before enabling this policy. The Port Grouping policy must be enabled before you can enable Device Load Balancing.

Manually created mappings from devices to N_Ports take precedence over automatically created mappings. Refer to “[Mapping priority](#)” on page 28 for details on connection priority for AG port mapping. For more information on device mapping, refer to “[Device mapping](#)” on page 22.

Enabling the Device Load Balancing policy

Use the following steps to enable Device Load Balancing.

1. Connect to the switch and log in using an account assigned to the admin role.
2. Enter the **configUpload** command to save the switch’s current configuration.
3. The Port Grouping policy must be enabled to enable Device Load Balancing. Enter the **ag –policyshow** command to determine if the Port Grouping policy is enabled. If it is not enabled, enter **ag –policyenable pg** to enable this policy.
4. Enter the **ag --policyenable wwnloadbalance** command to enable the Device Load Balancing policy. Because Fibre Channel devices are identified by their WWNs, CLI commands use device WWNs.

Disabling the Device Load Balancing policy

Before disabling this policy, you should save the configuration using the **configUpload** command in case you need this configuration again.

1. Connect to the switch and log in using an account assigned to the admin role.
2. Enter the **ag --policydisable wwnloadbalance** command to disable the Device Load Balancing policy.
3. Enter the **ag –policyshow** command to determine the current status of the Device Load Balancing policy.

Device Load Balancing policy considerations

- The Device Load Balancing policy should be enabled on the edge AG of a cascaded AG configuration.
- The Device Load Balancing policy is not applicable on a port group when the APC policy or Automatic Login Balancing are enabled.
- If a device is mapped to a port that is currently part of a trunk, then the device will use that trunk. When trunking is used with the Device Load Balancing policy, then the load on each trunk will be proportional to the number of ports in that trunk. Use the **ag -show** command to determine the devices using a particular trunk.
- When using the Device Load Balancing policy, make sure that all ports in the port group have the same NPIV login limit. If some ports have a lower login limit than the other ports, and there are many logins to the group, some devices will repeatedly attempt to connect to the device with the lower limit (because it has the fewest logins) and fail to connect.

Persistent ALPA policy

The Persistent ALPA policy is meant for host systems with operating systems that cannot handle different PID addresses across login sessions when booting over a SAN. The Persistent ALPA policy for switches in Access Gateway mode allows you to configure the AG module so that the host is more likely to get the same PID when it logs out of and into the same F_Port. Because the Arbitrated Port Loop Address (ALPA) field makes up a portion of the PID, the PID may change across switch or server power cycles. This policy, if enabled, helps reduce the chances of a different PID being issued for the same host.

The benefit of this policy is that it ensures that a host has the same ALPA on the F_Ports through the host power cycle. You can also achieve the same behavior and benefit by setting the same policy in the main (core) fabric. When this policy is enabled, AG will request the same ALPA from the core fabric. However, depending on the fabric, this request may be denied. When this occurs, the host is assigned a different ALPA. The following modes deal with this situation:

- In “Flexible” mode, the AG logs an event that it did not receive the same (requested) ALPA from the core fabric and brings up the device with the ALPA assigned by the fabric.
- In the “Stringent” mode, if the requested ALPA is not available, the server login will be rejected and the server port cannot log in to the fabric.

Enabling the Persistent ALPA policy

By default, Persistent ALPA is disabled. You can enable Persistent ALPA using the **ag --persistentalpaenable** command with the following syntax and with one of the following value types:

```
ag -persistentalpaenable 1/0[On/Off] -s/-f[Stringent/Flexible]
```

- Flexible ALPA assigns an unassigned ALPA value when the ALPA assigned to the device is taken by another host.
- Stringent ALPA causes the host login request to be rejected by AG if assignment of the same ALPA is not possible.

To enable Persistent ALPA, use the following steps.

1. Connect to the switch and log in using an account assigned to the admin role.
2. Enter the **ag --persistentalpaenable** command to enable persistent ALPA in flexible (-f) or stringent (-s) mode. The following example shows enabling the policy in flexible mode.

```
switch:admin> ag --persistentalpaenable 1 -f
```

To ensure consistency among the different devices, after Persistent ALPA is enabled, all the ALPAs become persistent, whether or not they were logged in before the Persistent ALPA policy was enabled.

Disabling the Persistent ALPA policy

When you disable this policy, do not specify the value type (for example, flexible ALPA or stringent ALPA). Use the following steps.

1. Connect to the switch and log in using an account assigned to the admin role.
2. Enter the **ag --persistentalpadisable** command.

```
switch:admin> ag --persistentalpaenable 0
```

Persistent ALPA device data

Access Gateway uses a table to maintain a list of available and used ALPAs. When the number of entries in this table is exhausted, the host receives an error message. You can remove some of the entries to make space using the instructions in [“Removing device data from the database”](#).

Removing device data from the database

Use the following steps to remove device data from the database.

1. Connect to the switch and log in using an account assigned to the admin role.
2. Enter the **ag --deletepwnfromdb** command.

```
switch:admin> ag --deletepwnfromdb PWWN
```

In the example, PWWN is the port that you want to remove from the database.

Displaying device data

You can view the ALPA of the host related to any ports you delete from the database.

1. Connect to the switch and log in using an account assigned to the admin role.
2. Enter the **ag --printalpamap** command with the appropriate option to display a database entry for a specific F_Port. The following example will display an entry for F_Port 2.

```
switch:admin> ag --printalpamap 2
```

Clearing ALPA values

You can clear the ALPA values for a specific port.

1. Connect to the switch and log in using an account assigned to the admin role.
2. Enter the **ag --clearalpamap** command with the appropriate option to remove the PWW-to-ALPA mapping for a specific port. In the following example, the mapping for port 2 is cleared from the database.

```
switch:admin> ag --clearalpamap 2
```

NOTE

All the device data must be persistent in case of a reboot. During a reboot, the tables will be dumped to the `persistent_NPIV_config` file.

Persistent ALPA policy considerations

The Persistent ALPA policy is not supported in the following situations:

- When AG N_Ports are connected to the shared ports of 48-port Director blades.
- Cisco fabrics. Enable Persistent FCID mode on the connecting Cisco switch to achieve the same functionality.
- Persistent ALPA configuration will not change to the default when the **configDefault** command is used, but will retain the previous configuration.

Failover policy

The Access Gateway Failover policy ensures maximum uptime for the servers. When a port is configured as an N_Port, the Failover policy is enabled by default and is enforced during power-up. The Failover policy allows hosts and targets to automatically remap to another online N_Port if the primary N-Port goes offline.

NOTE

For port mapping, the Failover policy must be enabled on an N_Port for failover to occur. For device mapping, if a device is mapped to an N_Port in a port group, the device will always reconnect to the least-loaded online N_Port in the group (or secondary N_Port in the group if configured) if the primary N_Port goes offline. This occurs regardless of whether the Failover policy is enabled or disabled for the primary N_Port.

Failover with port mapping

The Failover policy allows F_Ports to automatically remap to an online N_Port if the primary N_Port goes offline. If multiple N_Ports are available for failover, the Failover policy evenly distributes the F_Ports to available N_Ports belonging to the same N_Port group. If no other N_Port is available, failover does not occur and the F_Ports mapped to the primary N_Port go offline as well.

AG provides an option to specify a secondary failover N_Port for an F_Port.

NOTE

If failover and failback policy are disabled, an F_Port mapped to an N_Port will go offline when the N_Port goes offline and it will go online when the N_Port comes online.

Failover configurations in Access Gateway

The following sequence describes how a failover event occurs:

- An N_Port goes offline.
- All F_Ports mapped to that N_Port are temporarily disabled.
- If the Failover policy is enabled on an offline N_Port, the F_Ports mapped to it will be distributed among available online N_Ports. If a secondary N_Port is defined for any of these F_Ports, these F_Ports will be mapped to those N_Ports. If the Port Grouping policy is enabled, then the F_Ports only fail over to N_Ports that belong to the same port group as the originally offline N_Port.

Failover example

The following example shows the failover sequence of events in a scenario where two fabric ports go offline, one after the other. Note that this example assumes that no preferred secondary N_Port is set for any of the F_Ports.

- First, the Edge switch F_A1 port goes offline, as shown in [Figure 11](#) on page 52 Example 1 (left), causing the corresponding Access Gateway N_1 port to be disabled.
The ports mapped to N_1 fail over; F_1 fails over to N_2 and F_2 fails over to N_3.
- Next, the F_A2 port goes offline, as shown in [Figure 11](#) on page 52 Example 2 (right), causing the corresponding Access Gateway N_2 port to be disabled.
The ports mapped to N_2 (F_1, F_3, and F_4) fail over to N_3 and N_4. Note that the F_Ports are evenly distributed to the remaining online N_Ports and that the F_2 port did not participate in the failover event.

3 Failover policy

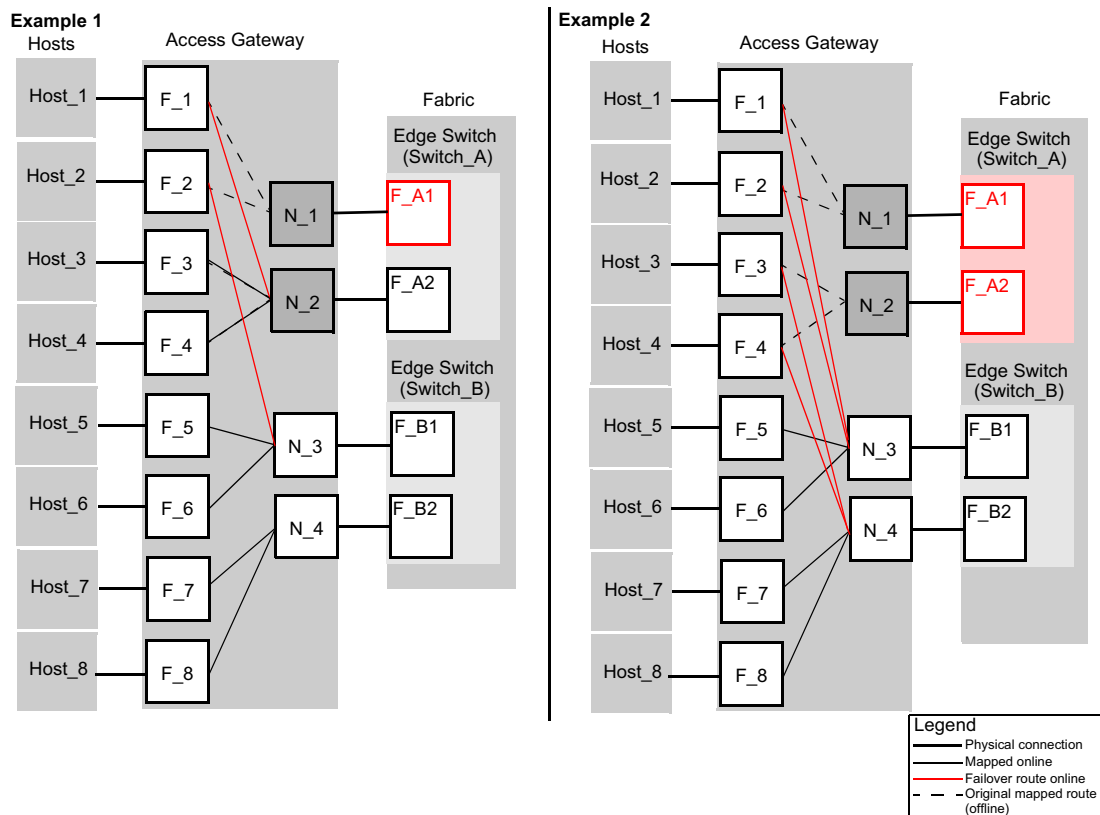

FIGURE 11 Failover behavior

Adding a preferred secondary N_Port (optional)

F_Ports automatically fail over to any available N_Port. Alternatively, you can specify a preferred secondary N_Port in case the primary N_Port fails. If the primary N_Port goes offline, the F_Ports fail over to the preferred secondary N_Port (if it is online), then re-enable. If the secondary N_Port is offline, the F_Ports will disable. Define the preferred secondary N_Ports per F_Port. For example, if two F_Ports are mapped to a primary N_Port, you can define a secondary N_Port for one of those F_Ports and not define a secondary N_Port for the other F_Port. F_Ports must have a primary N_Port mapped before a secondary N_Port can be configured.

1. Connect to the switch and log in using an account assigned to the admin role.
2. Enter the **ag --prefset** command with the “F_Port1;F_Port2; ...” N_Port options to add the preferred secondary F_Ports to the specified N_Port.

The F_Ports must be enclosed in quotation marks and the port numbers must be separated by a semicolon, as shown in the following example.

```
switch:admin> ag --prefset "3,9" 4
Preferred N_Port is set successfully for the F_Port[s]
```

NOTE

Preferred mapping is not allowed when Automatic Login Balancing mode is enabled for a port group. All N_Ports are the same when Automatic Login Balancing mode is enabled.

Deleting F_Ports from a preferred secondary N_Port

1. Connect to the switch and log in using an account assigned to the admin role.
2. Enter the **ag --prefdel** command with the “F_Port1;F_Port2;...” N_Port options to delete F_Ports from an N_Port.

The list of F_Ports must be enclosed in quotation marks. Port numbers must be separated by a semicolon. In the following example, F_Ports 3 and 9 are deleted from preferred secondary N_Port 4.

```
switch:admin> ag --prefdel "3;9" 4
Preferred N_Port is deleted successfully for the F_Port[s]
```

Failover with device mapping

Failover is handled similarly for port mapping and device mapping if devices are mapped to N_Port groups. If a device is mapped to an N_Port in a group, and an N_Port goes offline, the devices mapped to that N_Port will reconnect on the least-loaded online N_Ports in the group.

Enabling or disabling the Failover or Failback policies for N_Ports has no effect on device mapping. A device will always fail over to an online N_Port in the port group, regardless of whether the Failback policy is enabled for an N_Port or not. Whereas, with port mapping, if you disable the Failover or Failback policy on an N_Port, the F_Port will not fail over or fail back to other N_Ports.

Failover behavior is different if a device is mapped to a specific N_Port instead of to an N_Port group. If mapping a device to a specific N_Port, you can define a secondary N_Port that will be used if the primary N_Port is offline. To maximize the device uptime, it is recommended to map the device to a port group rather than to specific N_Ports.

Adding a preferred secondary N-Port for device mapping (optional)

Use the following steps to configure a secondary N_Port where devices will connect if their first or primary N_Port, if defined, is unavailable.

1. Connect to the switch and log in using an account assigned to the admin role.
2. To configure an N_Port as a failover port for one or multiple devices mapped to a specific N_Port, enter the **ag --addwwnfailovermapping N_Port** command with the “[WWN];[WWN]” option. All of the listed device WWNs will use the listed N_Port if it is available and the first mapped N_Port is unavailable.

The following example configures N_Port 32 as the failover port for two devices already mapped to a primary N_Port.

```
ag --addwwnfailovermapping 32
"10:00:00:06:2b:0f:71:0c;10:00:00:05:1e:5e:2c:11"
```

To configure N_Port 32 as a failover port for all WWNs mapped to the N_Port, enter the **ag --addwwnfailovermapping N_Port** command with the *--all* option.

```
ag --addwwnfailovermapping 32--all
```

Deleting a preferred secondary N_Port for device mapping (optional)

Use the following steps to remove a secondary N_Port where devices will connect if their first or primary N_Port, if defined, is unavailable.

1. Connect to the switch and log in using an account assigned to the admin role.
2. To delete an N_Port configured as a failover port for one or multiple devices mapped to a specific N_Port, enter the **ag --delwwnfailovermapping N_Port** command with the “[WWN];[WWN]” option. All of the listed devices will stop using the N_Port if the first N_Port mapped to the devices is unavailable unless they log in through F_Ports that are mapped to the N_Port.

The following example removes N_Port 32 as the secondary N_Port for two devices already mapped to a primary N_Port.

```
ag --delwwnfailovermapping 32
"10:00:00:06:2b:0f:71:0c;10:00:00:05:1e:5e:2c:11"
```

To remove an N_Port as a failover port for all devices mapped to the N_Port, enter the **ag --delwwnfailovermapping N_Port** command with the **--all** option.

The following command removes N_Port 32 as the secondary N_Port for all available devices.

```
ag --delwwnfailovermapping 32--all
```

Enabling and disabling the Failover policy on an N_Port

Use the following steps to enable or disable the Failover policy on a specific N_Port.

1. Connect to the switch and log in using an account assigned to the admin role.
2. Enter the **ag --failovershow N_Port** command to display the failover setting.

```
switch:admin> ag --failovershow 13
Failover on N_Port 13 is not supported
```

3. Enter the **ag --failoverenable N_Port** command to enable failover.

```
switch:admin> ag --failoverenable 13
Failover policy is enabled for port 13
```

4. Enter the **ag --failoverdisable N_Port** command to disable failover.

```
switch:admin> ag --failoverdisable 13
Failover policy is disabled for port 13
```

Enabling and disabling the Failover policy for a port group

The Failover policy can be enabled on a port group. Use the following steps to enable or disable the failover on all the N_Ports belonging to the same port group.

1. Connect to the switch and log in using an account assigned to the admin role.
2. Enter the **ag --failoverenable -pg pgid** command to enable failover.

```
switch:admin> ag --failoverenable -pg 3
Failover policy is enabled for port group 3
```

3. Enter the `ag --failoverdisable -pg pgid` command to disable failover.

```
switch:admin> ag --failoverdisable -pg 3
Failover policy is disabled for port group 3
```

Upgrade and downgrade considerations for the Failover policy

Consider the following when upgrading or downgrading Fabric OS versions:

- Downgrading to Fabric OS v6.4.0 or earlier is supported.
- Upgrading from Fabric OS v6.4.0 to v7.1.0 or downgrading from Fabric OS v7.1.0 to v6.4.0 will not change failover settings.

Failback policy

The Failback policy provides a means for hosts that have failed over to automatically reroute back to their intended mapped N_Ports when these N_Ports come back online. The Failback policy is an attribute of an N_Port and is enabled by default when a port is locked to the N_Port.

Only the originally mapped F_Ports fail back. In the case of multiple N_Port failures, only F_Ports that were mapped to a recovered N_Port experience failback. The remaining F_Ports are not redistributed.

NOTE

For port mapping, the Failback policy must be enabled on an N_Port for failback to occur. For device mapping, the Failback policy has no effect. If a device is mapped to a port group, it will always fail over to an online N_Port in the port group (or secondary N_Port if configured) and will remain connected to this failover N_Port when the original N_Port comes back online.

NOTE

If failover and failback policy are disabled, an F_Port mapped to an N_Port will go offline when the N_Port goes offline and it will go online when the N_Port comes online.

Failback policy configurations in Access Gateway

The following sequence describes how a failback event occurs:

- When an N_Port comes back online, with the Failback policy enabled, the F_Ports that were originally mapped to it are temporarily disabled.
- The F_Port is rerouted to the primary mapped N_Port, and then re-enabled.
- The host establishes a new connection with the fabric.

NOTE

The failback period is quite fast and rarely causes an I/O error at the application level.

Failback example

In Example 3, described in [Figure 12](#) on page 56, the Access Gateway N_1 remains disabled because the corresponding F_A1 port is offline. However, N_2 comes back online. See [Figure 11](#) on page 52 for the original failover scenario.

3 Failback policy

Ports F_1 and F_2 are mapped to N_1 and continue routing to N_3. Ports F_3 and F_4, which were originally mapped to N_2, are disabled and rerouted to N_2, and then enabled.

Example 3

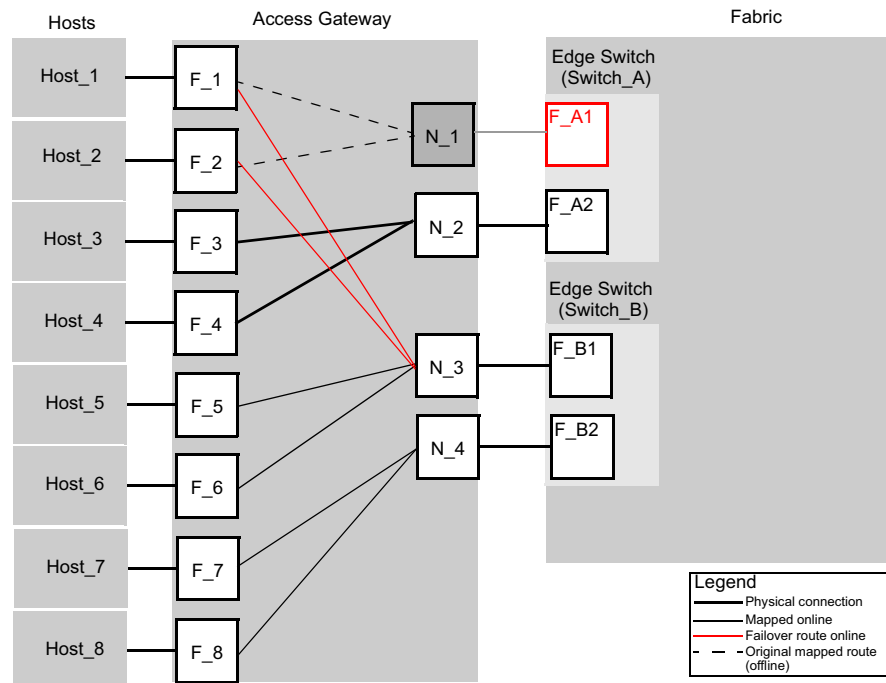

FIGURE 12 Failback behavior

Enabling and disabling the Failback policy on an N_Port

Use the following steps to enable or disable the Failback policy on N_Ports.

1. Connect to the switch and log in using an account assigned to the admin role.
2. Enter the **ag --failbackshow n_portnumber** command to display the failback setting.

```
switch:admin> ag --failbackshow 13
Failback on N_Port 13 is not supported
```

3. Use the following commands to enable or disable the Failback policy:

- Enter the **ag --failbackenable n_portnumber** command to enable failback.

```
switch:admin> ag --failbackenable 13
Failback policy is enabled for port 13
```

Enter the **ag --failbackdisable n_portnumber** command to disable failback.

```
switch:admin> ag --failbackdisable 13
Failback policy is disabled for port 13
```

Enabling and disabling the Failback policy for a port group

Use the following steps to enable or disable the Failback policy on all the N_Ports belonging to the same port group.

1. Connect to the switch and log in using an account assigned to the admin role.
2. Use the following commands to enable or disable the Failback policy for a port group:
 - Enter the **ag --failbackenable pg *pgid*** command to enable failback on a port group.

```
switch:admin> ag --failbackenable -pg 3
Failback policy is enabled for port group 3
```
 - Enter the **ag --failbackdisable pg *pgid*** command to disable failback on a port group.

```
switch:admin> ag --failbackdisable -pg 3
Failback policy is disabled for port group 3
```

Upgrade and downgrade considerations for the Failback policy

- Downgrading to Fabric OS v6.3.0 or earlier is supported.
- Upgrading from Fabric OS v6.4.0 is supported.

Failback policy disabled on unreliable links (N_Port monitoring)

Links from all N_Ports are monitored for the number of online and offline static change notifications (SCNs) that occur during a set time period (5 minutes). If the number of SCNs on a link exceeds a set threshold, the link is considered unreliable, and failback is disabled for that N_Port. Failover continues for the port as needed. Once the number of SCNs drops below the set threshold, the port is deemed reliable again and failback is re-enabled. If the link from a preferred secondary N_Port for an F_Port becomes unreliable, failover will not occur to that N_Port.

The default threshold is 25 SCNs per 5 minutes. You can modify the SCN threshold counter using the following command.

```
ag --reliabilitycounterset "count"
```

You can view counter settings using the following command.

```
ag --reliabilitycountershow
```

Considerations for Failback policy disabled on unreliable links

Consider the following when an N_Port link becomes reliable again after being unreliable:

- Preferred N_Port settings are enforced.
- If failback is enabled, configured F_Ports will fail back to the N_Port.
- If the configured F_Ports are offline, they will go back online.
- If Device Load Balancing is enabled, rebalancing occurs.

Trunking in Access Gateway mode

The hardware-based Port Trunking feature enhances management, performance, and reliability of Access Gateway N_Ports when they are connected to Brocade fabrics. Port trunking combines multiple links between the switch and AG module to form a single, logical port. This enables fewer individual links, thereby simplifying management. This also improves system reliability by maintaining in-order delivery of data and avoiding I/O retries if one link within the trunk fails. Equally important is that framed-based trunking provides maximum utilization of links between the AG module and the core fabric.

Trunking allows transparent failover and failback within the trunk group. Trunked links are more efficient because of the trunking algorithm implemented in the switching ASICs that distributes the I/O more evenly across all the links in the trunk group.

Trunking in Access Gateway is mostly configured on the Edge switch. To enable this feature, you must install the Brocade ISL license on both the Edge switch and the module running in AG mode and ensure that both modules are running the same Fabric OS version. If a module already has an ISL trunking license, no new license is required. After the trunking license is installed on a switch in AG mode and you change the switch to standard mode, you can keep the same license.

NOTE

N_Port trunking is not supported to HBAs connected to switches running in Access Gateway mode. N_Port trunking is only supported for HBAs connected to switches running in Native mode.

NOTE

You can also enable F_Ports on the Access Gateway switch for trunking using the **portcfgtrunkport** command.

How trunking works

Trunking in Access Gateway mode provides a trunk group between N_Ports on the AG module and F_Ports on the Edge switch module. With trunking, any link within a trunk group can go offline or become disabled, but the trunk remains fully functional and no reconfiguration is required. Trunking prevents reassignments of the port ID when N_Ports go offline.

Configuring trunking on the Edge switch

Because AG trunking configuration is mostly on the Edge switch, information in this section is applicable to the Edge switch module and not the AG module. On the AG module, you only need to ensure that the trunking license is applied and enabled. On the Edge switch, you must first configure an F_Port trunk group and statically assign an Area_ID to the trunk group. Assigning a Trunk Area (TA) to a port or trunk group enables F_Port masterless trunking on that port or trunk group. On switches running in Access Gateway mode, the masterless trunking feature trunks N_Ports because these are the only ports that connect to the Enterprise fabric. When a TA is assigned to a port or trunk group, the ports will immediately acquire the TA as the area of its port IDs (PIDs). When a TA is removed from a port or trunk group, the port reverts to the default area as its PID.

NOTE

By default, trunking is enabled on all N_Ports of the AG; ensure that this feature is enabled on N_Ports that are part of a port trunk group.

Trunk group creation

Port trunking is enabled between two separate Fabric OS switches that support trunking and where all the ports on each switch reside in the same quad and are running the same speed. Trunk groups form when you connect two or more cables on one Fabric OS switch to another Fabric OS switch with ports in the same port group or quad. A port group or a quad is a set of sequential ports; for example, ports 0-3. The Brocade 300 switch supports a trunk group with up to eight ports. The trunking groups are based on the user port number, with eight contiguous ports as one group, such as 0-7, 8-15, 16-23 and up to the number of ports on the switch.

Setting up trunking

Use the following steps to set up trunking.

1. Connect to the switch and log in using an account assigned to the admin role.
2. Ensure that both modules (Edge switch and the switch running in AG mode) have the trunking licenses enabled.
3. Ensure that the ports have trunking enabled by issuing the **portcfgshow** command. If trunking is not enabled, issue the **portcfgtrunkport [slot/] port, 1** command.
4. Ensure that the ports within a trunk have the same speed.
5. Ensure that the ports within an ASIC trunk group are used to group the ports as part of a trunk on the Edge switch or on an AG.
6. Ensure that both modules are running the same Fabric OS versions.

Configuration management for trunk areas

The **porttrunkarea** command does not allow ports from different admin domains (ADs) and ports from different logical switches to join the same trunk area (TA) group.

When you assign a TA, the ports within the TA group will have the same Index. The Index that was assigned to the ports is no longer part of the switch. Any Domain,Index (D,I) AD that was assumed to be part of the domain may no longer exist for that domain because it was removed from the switch.

Trunk area assignment example

If you have AD1: 3,7; 3,8; 4,13; 4,14 and AD2: 3,9; 3,10, and then create a TA with Index 8 with ports that have index 7, 8, 9, and 10. Then index 7, 9, and 10 are no longer with domain 3. This means that AD2 does not have access to any ports because index 9 and 10 no longer exist on domain 3. This also means that AD1 no longer has 3,7 in effect because Index 7 no longer exists for domain 3. AD1's 3,8, which is the TA group, can still be seen by AD1 along with 4,13 and 4,14.

A port within a TA can be removed, but this adds the Index back to the switch. For example, the same AD1 and AD2 with TA 8 holds true. If you remove port 7 from the TA, it adds Index 7 back to the switch. That means AD1's 3,7 can be seen by AD1 along with 3,8; 4,13 and 4,14.

Assigning a trunk area

You must enable trunking on all ports to be included in a trunk area before you can create a trunk area. Use the **portCfgTrunkPort** or **switchCfgTrunk** command to enable trunking on a port or on all ports of a switch.

Issue the **porttrunkarea** command to assign a static TA on a port or port trunk group, to remove a TA from a port or group of ports in a trunk, and to display masterless trunking information.

You can remove specified ports from a TA using the **porttrunkarea --disable** command, however, this command does not unassign a TA if its previously assigned Area_ID is the same address identifier (Area_ID) of the TA unless all the ports in the trunk group are specified to be unassigned. For more information on the **porttrunkarea** command, enter **help porttrunkarea** or see the *Fabric OS Command Reference Manual*. F_Port trunking will not support shared area ports 16-47 on the Brocade FC8-48 blades.

Table 9 shows an example of the address identifier.

TABLE 9 Address identifier

23	22	21	20	19	18	17	16	15	14	13	12	11	10	9	8	7	6	5	4	3	2	1	0
Domain ID								Area_ID								Port ID							
Address Identifier																							

1. Connect to the switch and log in using an account assigned to the admin role.
2. Disable the ports to be included in the TA.
3. Enable a TA for the appropriate ports. The following example enables a TA for ports 13 and 14 on slot 10 with port index of 125.

```
switch:admin> porttrunkarea --enable 10/13-14 -index 125
```

4. Display the TA port configuration (ports still disabled) using the **porttrunkarea --show enabled** command.
5. Enable the ports specified in step 3 using the **portenable** command.

```
switch:admin> portenable 10/13
switch:admin> portenable 10/14
```

6. Show the TA port configuration after enabling the ports using the **porttrunkarea --show enabled** command. The ports that you enabled should appear in the output.

Enabling the DCC policy on a trunk

After you assign a Trunk Area, the **porttrunkarea** command checks whether there are any active Device Connection Control (DCC) policies on the port with the index TA, and then issues a warning to add all the device WWNs to the existing DCC policy with index as TA. All DCC policies that refer to an Index that no longer exist will not be in effect.

Use the following steps to enable the DCC policy on a trunk.

1. Add the WWN of all the devices to the DCC policy against the TA.
2. Enter the **secpolicyactivate** command to activate the DCC policy.

You must enable the TA before issuing the **secpolicyactivate** command in order for security to enforce the DCC policy on the trunk ports.

3. Turn on the trunk ports.

Trunk ports should be turned on after issuing the **secpolicyactivate** command to prevent the ports from becoming disabled in the case where there is a DCC security policy violation.

Enabling trunking

1. Connect to the switch and log in using an account assigned to the admin role.
2. Disable the desired ports by entering the **portdisable port** command for each port to be included in the TA.
3. Enter the **porttrunkarea --enable 3** command with the appropriate options to form a trunk group for the desired ports. For example, if ports 36-39 were disabled in step 2, then the following example command forms a trunk group for ports 36-39 with index 37. These will be connected to N_Ports on an AG module.

```
switch:admin> porttrunkarea --enable 36-39 -index 37
Trunk area 37 enabled for ports 36, 37, 38 and 39.
```

4. Enter the **portenable port** command for each port in the TA to re-enable the desired ports, such as ports 36-39.
5. Enter the **switchhow** command to display the switch or port information, including created trunks.

Disabling F_Port trunking

Use the following steps to disable F_Port trunking.

1. Connect to the switch and log in using an account assigned to the admin role.
2. Enter the **porttrunkarea --disable** command.

```
switch:admin> porttrunkarea --disable 36-39
ERROR: port 36 has to be disabled
```

If an error occurs as in the previous example, disable each port using the **portdisable port** command, and then reissue the command.

```
switch:admin> porttrunkarea --disable 36-39
trunk area 37 disabled for ports 36, 37, 38 and 39.
```

Monitoring trunking

For F_Port masterless trunking, you must install Filter, EE, or TT monitors on the F_Port trunk port. Whenever the master port changes, it is required to move the monitor to the new master port. For example, if a master port goes down, a new master is selected from the remaining slave ports. The Advanced Performance Monitor (APM) must delete the monitor from the old master and install the monitor on the new master port. If you attempt to add a monitor to a slave port, it is automatically added to the master port.

AG trunking considerations for the Edge switch

Table 10 describes the Access Gateway trunking considerations for the Edge switch.

TABLE 10 Access Gateway trunking considerations for the Edge switch

Category	Description
Area assignment	<p>You statically assign the area within the trunk group on the Edge switch. That group is the F_Port masterless trunk.</p> <p>The static trunk area you assign must fall within the F_Port trunk group starting from port 0 on an Edge switch or blade.</p> <p>The static trunk area you assign must be one of the port's default areas of the trunk group.</p>
Authentication	<p>Authentication occurs only on the F_Port trunk master port and only once per the entire trunk. This behavior is the same as E_Port trunk master authentication. Because only one port in the trunk does FLOGI to the switch, and authentication follows FLOGI on that port, only that port displays the authentication details when you issue the portshow command.</p> <p>Note: Authentication is also supported on switches configured in AG mode.</p>
Management Server	<p>Registered Node ID (RNID), Link Incident Record Registration (LIRR), and Query Security Attributes (QSA) Extended Link Service Requests (ELs) are not supported on F_Port trunks.</p>
Trunk area	<p>The port must be disabled before assigning a Trunk Area on the Edge switch to the port or removing a Trunk Area from a trunk group.</p> <p>You cannot assign a Trunk Area to ports if the standby CP is running a firmware version earlier than Fabric OS v6.2.0.</p>
PWWN	<p>The entire Trunk Area trunk group shares the same Port WWN within the trunk group. The PWWN is the same across the F_Port trunk that will have 0x2f or 0x25 as the first byte of the PWWN. The TA is part of the PWWN in the format listed in Table 11 on page 65.</p>
Downgrade	<p>You can have trunking on, but you must disable the trunk ports before performing a firmware downgrade.</p> <p>Note: Removing a Trunk Area on ports running traffic is disruptive. Use caution before assigning a Trunk Area if you need to downgrade to a firmware earlier than Fabric OS v6.1.0.</p>
Upgrade	<p>No limitations on upgrade to Fabric OS 7.1.0 if the F_Port is present on the switch. Upgrading is not disruptive.</p>
HA Sync	<p>If you plug in a standby CP with a firmware version earlier than Fabric OS v6.1.0 and a Trunk Area is present on the switch, the CP blades will become out of sync.</p>
Port Types	<p>Only F_Port trunk ports are allowed on a Trunk Area port. All other port types that include F/FL/E/EX are persistently disabled.</p>

TABLE 10 Access Gateway trunking considerations for the Edge switch (Continued)

Category	Description
Default Area	Port X is a port that has its Default Area the same as its Trunk Area. The only time you can remove port X from the trunk group is if the entire trunk group has the Trunk Area disabled.
portCfgTrunkPort [slot/] port, 0	portCfgTrunkPort [slot/] port, 0 will fail if a Trunk Area is enabled on a port. The port must be Trunk Area-disabled first.
switchCfgTrunk 0	switchCfgTrunk 0 will fail if a port has TA enabled. All ports on a switch must be TA disabled first.
Port Swap	When you assign a Trunk Area to a Trunk group, the Trunk Area cannot be port swapped; if a port is swapped, then you cannot assign a Trunk Area to that port.
Trunk Master	No more than one trunk master in a trunk group. The second trunk master will be persistently disabled with reason "Area has been acquired".
Fast Write	When you assign a Trunk Area to a trunk group, the trunk group cannot have fast write enabled on those ports; if a port is fast-write-enabled, the port cannot be assigned a Trunk Area.
FICON	FICON is not supported on F_Port trunk ports. However, FICON can still run on ports that are not F_Port trunked within the same switch.
FC8-48 blades	F_Port trunking does not support shared area ports on the Brocade FC8-48 blades in a 48000. F_Port trunking is supported on all ports on the Brocade FC8-48 in the DCX and DCX-4S.
FC4-32 blade	If an FC4-32 blade has the Trunk Area enabled on ports 16 - 31 and the blade is swapped with a FC8-48 blade, the Trunk Area ports will be persistently disabled. You can run the porttrunkarea command to assign a Trunk Area on those ports.
Trunking	You must first enable trunking on the port before the port can have a Trunk Area assigned to it.
PID format	F_Port masterless trunking is only supported in CORE PID format.
Long Distance	Long distance is not allowed when AG is enabled on a switch. This means you cannot enable long distance on ports that have a Trunk Area assigned to them.
Port mirroring	Port mirroring is not supported on Trunk Area ports or on the PID of an F_Port trunk port.
Port speed	Ports within a trunk must have the same port speed for a trunk to successfully be created.

3 Trunking in Access Gateway mode

TABLE 10 Access Gateway trunking considerations for the Edge switch (Continued)

Category	Description
configDownload and configUpload	<p>If you issue the configdownload command for a port configuration that is not compatible with F_Port trunking, and the port is Trunk-Area-enabled, then the port will be persistently disabled.</p> <p>Note: Configurations that are not compatible with F_Port trunking are long distance, port mirroring, non-CORE_PID, and Fast Write.</p> <p>If you issue the configupload command, consider the following:</p> <ul style="list-style-type: none"> • A configuration file uploaded when AG mode is disabled cannot be downloaded when AG mode is enabled. • A configuration file uploaded when AG mode is enabled cannot be downloaded when AG mode is disabled. • A configuration file uploaded when the PG policy is enabled cannot be downloaded when the APC policy is enabled. • A configuration file uploaded when the APC policy is enabled cannot be downloaded when the PG policy is enabled.
ICL port	F_Port trunks are not allowed on ICL ports. The porttrunkarea command does not allow it.
AD	You cannot create a Trunk Area on ports with different Admin Domains. You cannot create a Trunk Area in AD255.
DCC Policy	DCC policy enforcement for the F_Port trunk is based on the Trunk Area; the FDISC request to a trunk port is accepted only if the WWN of the attached device is part of the DCC policy against the TA. The PWWN of the FLOGI sent from the AG will be dynamic for the F_Port trunk master. Because you do not know ahead of time what PWWN AG will use, the PWWN of the FLOGI will not go through DCC policy check on an F_Port trunk master. However, the PWWN of the FDISC will continue to go through DCC policy check.
D,I Zoning (D,I) AD (D, I) DCC and (PWWN, I) DCC	<p>Creating a Trunk Area may remove the Index (“I”) from the switch to be grouped to the Trunk Area. All ports in a Trunk Area share the same “I”. This means that Domain,Index (D,I), which refers to an “I”, that might have been removed, will no longer be part of the switch.</p> <p>Note: Ensure to include AD, zoning, and DCC when creating a Trunk Area.</p> <p>You can remove the port from the Trunk Area to have the “I” back into effect. D,I will behave as normal, but you may see the effects of grouping ports into a single “I”.</p> <p>Also, D,I continues to work for Trunk Area groups. The “I” can be used in D,I if the “I” was the “I” for the Trunk Area group.</p> <p>Note: “I” refers to Index and D,I refers to Domain,Index.</p>
Two masters	Two masters is not supported in the same F_Port trunk group.
QoS	Supported.

Table 11 describes the PWWN format for F_Port and N_Port trunk ports.

TABLE 11 PWWN format for F_Port and N_Port trunk ports

NAA = 2	2f:xx:nn:nn:nn:nn:nn:nn (1)	Port WWNs for: switch FX_Ports.	The valid range of xx is [0 - FF], for maximum of 256.
NAA = 2	25:xx:nn:nn:nn:nn:nn:nn (1)	Port WWNs for: switch FX_Ports	The valid range of xx is [0 - FF], for maximum of 256.

Trunking considerations for Access Gateway mode

Consider the following for trunking in Access Gateway mode:

- Access Gateway trunking is not supported on M-EOS or third-party switches.
- Trunk groups cannot span across multiple N_Port groups within an AG module in AG mode. Multiple trunk groups are allowed within the same N_Port group. All ports within a trunk group must be part of the same port group; ports outside of a port group cannot form a trunk group.
- The **ag -wwnmapshow** command will not display trunking for device-mapped ports. If a device is mapped to a port with device mapping and that port is currently part of a trunk, then the device will use that trunk. When trunking is used with the Device Load Balancing policy, then the load on each trunk will be proportional to the number of ports in that trunk. Use the **ag -show** command to determine the devices using a particular trunk.

Upgrade and downgrade considerations for trunking in Access Gateway mode

Upgrading to Fabric OS v7.1.0 and downgrading to Fabric OS v6.4.0 and earlier is supported.

Adaptive Networking on Access Gateway

Adaptive Networking (AN) services ensure bandwidth for critical servers, virtual servers, or applications in addition to reducing latency and minimizing congestion. Adaptive Networking in Access Gateway works in conjunction with the Quality of Service (QoS) feature on Brocade fabrics. Fabric OS provides a mechanism to assign traffic priority, (high, medium, or low) for a given source and destination traffic flow. By default, all flows are marked as medium.

You can configure the ingress rate limiting and SID/DID traffic prioritization levels of QoS for the following configurations:

- Supported HBA to AG to switch
- Unsupported HBA to AG to switch
- HBA (all) to Edge AG to Core AG to switch

For additional information on the QoS feature for Brocade adapters, refer to the Brocade Adapters Administrator's Guide.

QoS: Ingress rate limiting

Ingress rate limiting restricts the speed of traffic from a particular device to the switch port. On switches in AG mode, you must configure ingress rate limiting on F_Ports.

For more information and procedures for configuring this feature, refer to “Ingress Limiting” in the *Fabric OS Administrator’s Guide*.

QoS: SID/DID traffic prioritization

SID/DID traffic prioritization allows you to categorize the traffic flow between a given host and target as having a high or low priority; the default is medium. For example, you can assign online transaction processing (OLTP) to a high priority and the backup traffic to a low priority.

For detailed information on this feature, refer to “QoS: SID/DID traffic prioritization” in the *Fabric OS Administrator’s Guide*.

Figure 13 shows the starting point for QoS in various Brocade and non-Brocade configurations.

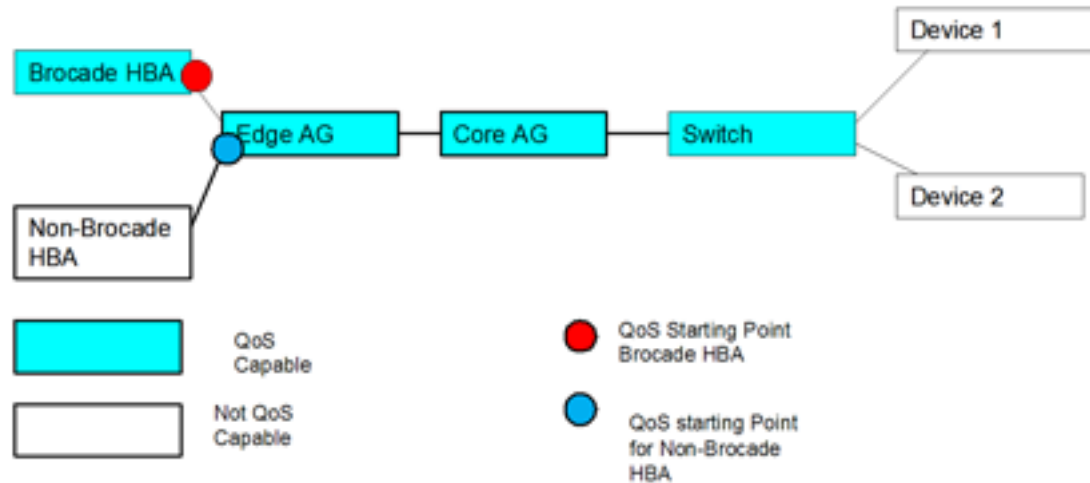

FIGURE 13 Starting point for QoS

Upgrade and downgrade considerations for Adaptive Networking in AG mode

Upgrading to Fabric OS v7.1.0 from Fabric OS v6.4.0 is supported. Note the following considerations when upgrading to Fabric OS v7.1.0 from Fabric OS v6.2.X and earlier and downgrading from Fabric OS v7.1.0 to Fabric OS v6.2.X and earlier:

- If any of the AG QoS-enabled ports are active and you attempt a firmware downgrade, the downgrade is prevented. You must disable the QoS-enabled ports before performing a firmware downgrade.
- Upgrades from earlier versions to Fabric OS v7.1.0 are allowed, but AG QoS-enabled ports do not become effective until the ports are disabled or enabled so that QoS mode can be negotiated on the ISLs.

Adaptive Networking on Access Gateway considerations

- QoS is configured in the fabric, as normal, and not on the AG module.
- QoS on Access Gateway is only supported on Fabric OS v6.3 and later.
- You should disable HBA QoS if connected to a Fabric OS v6.2 AG switch.
- Disable QoS on an AG port if it connects with a switch running Fabric OS v6.2. Otherwise, the port will automatically disable with an error. To recover, disable QoS on the port, and then enable the port.
- Disabling QoS on online N_Ports in the same trunk can cause the slave N_Port ID Virtualization (NPIV) F_Port on the Edge switch to become persistently disabled with “Area has been acquired.” This is expected behavior because after QoS is disabled, the slave NPIV F_Port on the Edge switch also tries to come up as a master. To avoid this issue, simply persistently enable the slave F_Port on the switch.
- QoS takes precedence over ingress rate limiting
- Ingress rate limiting is not enforced on trunked ports.

Per-Port NPIV login limit

The Per-Port NPIV login limit feature allows you to set a specific maximum NPIV login limit on individual ports. This feature works in both Native and Access Gateway modes. Using this feature, you can use additional tools to design and implement a virtual infrastructure. In Access Gateway mode, this feature allows smaller login limits for F_Ports and larger limits for N_Ports. Note that N_Ports are restricted by the NPIV login limit of the connecting port on the Edge switch.

Note the following aspects of this feature:

- Upgrading between Fabric OS v6.4.0 and v7.1.0 will retain the NPIV settings.
- The value that you set is persistent across reboots and firmware upgrades.
- This feature supports virtual switches, so each port can have a specific NPIV login limit value in each logical switch.
- The login limit default is 126. This value will be set for a port when the **portCfgDefault** command is used to reset port default values.
- Before changing the login limits, you must disable the port.
- This feature only applies to ports enabled for NPIV operation. To enable NPIV functionality for a port, you can use the **portCfgNPIVPort –enable** command when the switch is in Fabric OS Native mode. For details, refer to the *Fabric OS Command Reference Manual*.

Setting the login limit

Use the following procedure to set the NPIV login limit for a port.

1. Connect to the switch and log in using an account assigned to the admin role.
2. Disable the port by entering the **portdisable port** command.
3. Enter the **portcfgnpiv –setloginlimit [Slot/]Port loginlimit** command to set the login limit. For example, the following example sets the login limit on port 12 to 200.

```
portcfgnpivport --setloginlimit 12 200
```

Duplicate PWWN handling during device login

Handling of logins from two devices using the same PWWN follows standards for all Fabric OS switches. Having two devices with the same PWWN logged into the fabric at the same time may not be desirable as there have been cases when ports coming online get stuck in G_Port state in the AG switch. You can configure three policies:

- **Default** - The Access Gateway switch will not accept a second login request from a PWWN when a device with the same PWWN has already logged into the fabric. The second request with similar PWWN will be rejected and the port will be persistently disabled with reason as “Duplicate Port WWN detected.”
- **Enforced login** - The second login request will have precedence over the existing login and Access Gateway will accept the login.
- **Mixed** - This option takes port type into consideration. The second login request will have precedence over the existing login in case of a duplicate entry exit on the F_Port with an NPIV device logged in. The first login takes precedence over the second login request in case of a duplicate entry exit on the F_Port without any NPIV device logged in.

You can configure different handling of duplicate PWWNs other than the default operation using the **configure** command through the F_Port login parameters. For more information on configuration and handling of duplicate PWWNs during device login, refer to the “Duplicate PWWN handling during device login” section in the *Fabric OS Administrator’s Guide*.

This feature is supported in the following configurations:

- AG switch connected to AG switch in cascaded configuration.
- AG switch connected to Brocade fabric switch.
- AG switch connected to a Brocade Host Bus Adapter (HBA).

Performance Monitoring

Performance monitoring is available through the Flow Vision “Flow Monitor” for platforms using Fabric OS 7.2 and later. Legacy Advanced Performance Monitoring features are also an option.

Flow Monitor

Flow Vision is a licensed feature supported on platforms using Fabric OS 7.2 and later. It provides a unified platform to manage traffic-related applications on Fabric OS devices. Storage administrators can use this platform to simulate, monitor, and capture the network’s traffic patterns and to make capacity-planning decisions based on the collected statistical data.

To access Flow Vision, the Fabric Vision (FV) license or both the Fabric Watch (FW) and the Advanced Performance Monitor (APM) licenses must be installed on the hardware platform.

The Flow Monitor component of Flow Vision is supported by Access Gateway. Flow Monitor allows you to monitor the network’s traffic pattern and provides statistics to make capacity planning decisions based on the collected data. Flow Monitor provides a single interface to manage flows and unifies different performance monitoring features such as end-to-end monitors and frame monitors.

Flow Monitor expands on basic performance monitoring by allowing you to monitor any hardware-supported flow parameters and define your own flows using combinations of source and destination devices, source and destination IDs, LUN IDs, CSCTL values, and frame types as parameters.

Following are examples of monitors that you can replicate using Flow Monitor:

- End to End Monitor - This measures the traffic in terms of word count between a pair of ports (host and target). Use this to view end-to-end traffic values on an Access Gateway.
- Frame monitoring - Set up an SCSI monitor so that you can view the **-frametype** frame and byte count for a flow.
- LUN monitoring - This allows you to view the **-frametype** frame and byte count for a specific LUN.
- Flow learning monitor - This learns flows going through a specific F_Port in the Access Gateway.
- DST monitor - This provides the legacy support equivalent to a fmmonitor.

Access Gateway switches support flow monitors on F_Ports only, and only the ingress port parameter is supported. For more information on using Flow Monitor features for Access Gateway in Flow Vision, refer to the *Flow Vision Administrator's Guide*.

Legacy performance monitoring features

Instead of Flow Monitor, you can use the legacy end-to-end and frame monitoring features available through Advanced Performance Monitoring (APM). These legacy features are available on platforms using Fabric OS 7.2 and earlier. The following licenses must be appropriately installed on the AG switch to use the end-to-end and frame monitors:

- APM
- Fabric Watch

Use the following Fabric OS commands used to manage APM in switch mode to manage end to end and frame monitoring in AG mode. Refer to the *Fabric OS Command Reference Manual* and *Fabric OS Administrator's Guide* for details.

- **perfAddEEMonitor**
- **perfMonitorClear**
- **perfMonitorShow -class EE <port#>**
- **perfResourceShow**
- **perfCfgSave**
- **perfCfgClear**
- **perfCfgRestore**
- **fmmonitor**

You can also use Fabric Watch to configure thresholds corresponding to specific frame monitors. Refer to the *Fabric Watch Administrator's Guide* for details.

End-to-end monitors

End-to-end monitors measure the traffic between a host and target pair by counting the number of words in Fibre Channel frames for a specified Source ID (SID) and Destination ID (DID) pair. An end-to-end performance monitor includes these counts:

- RX_COUNT - Words in frames received at the port
- TX_COUNT - Words in frames transmitted from the port

To enable end-to-end performance monitoring, you must install an end-to-end monitor on an F_Port using the **perfAddEEMonitor** command, specifying the SID-DID pair (in hexadecimal). End-to-end monitoring on N-ports is not supported in AG mode. Complete details of the **perfAddEEMonitor** command parameters are provided in the *Fabric OS Command Reference Manual*.

NOTE

End-to-end monitors are not supported on logical EX, VE, VEX, Mirror, or FCoE ports.

For more information on end-to-end monitoring, including the following topics, refer to the “End-to-end performance monitoring” section in the *Fabric OS Administrator’s Guide*:

- General feature information
- Fabric OS commands for end-to-end monitors
- The maximum number of end-to-end monitors per switch model
- Setting a mask for a monitor
- Deleting a monitor

Frame monitors

Frame monitors count the number of times a frame with a particular pattern is transmitted by a port and generate alerts when thresholds are crossed. Frame monitoring is achieved by defining a filter, or frame type, for a particular purpose. The frame type can be a standard type (for example, an SCSI read command filter that counts the number of SCSI read commands that have been transmitted by the port) or a frame type that you can customize for a particular use. For a complete list of the standard, pre-defined frame types, see the **fmMonitor** command description in the *Fabric OS Command Reference Manual*.

To enable frame monitoring, you must install a frame monitor on an F_Port or N_Port in the AG switch using the **fmMonitor** command. Using options in this command, you can also perform the following tasks:

- Create a new frame type.
- Delete a specified frame type.
- Delete the set of ports on which the specified frame type can be monitored.
- Add a set of ports for which a specific frame type can be monitored.
- Save a set of ports on which the specified frame type can be monitored.
- Show different frame types configured on the switch, as well as frame counters.
- Change properties for a particular frame type, such as thresholds and bit pattern.
- Clear a set of ports on which the specified frame type is monitored to the persistent configuration.

Complete details of the **fmMonitor** command parameters are provided in the *Fabric OS Command Reference Manual*.

The **thConfig** command can be used for advanced configuration of filter thresholds corresponding to frame monitors. See the *Fabric Watch Administrator’s Guide* for more information about using this command.

For more information on frame monitoring, including the following topics, refer to the “Frame monitoring” section in the *Fabric OS Administrator’s Guide*:

- General feature information
- Maximum number of frame monitors and offsets per port for different switch models
- Virtual fabric considerations
- Adding frame monitors to a port
- Removing frame monitors from a port
- Creating custom frame types to be monitored
- Deleting frame types
- Saving frame monitor configurations
- Displaying frame monitors
- Clearing frame monitor counters

Limitations for using legacy APM features

The following limitations apply to using legacy APM features on an AG switch:

- The Top Talker and ISL monitoring features used for APM in switch mode are not supported on an AG switch.
- APM on an AG switch is not supported in Web Tools.
- Configuration file upload and download of end-to-end and filter monitor configurations is not supported in the Fabric OS v7.0.0 release.
- When downgrading to a pre-Fabric OS v7.0.0 release, the user is notified to remove all the end-to-end and frame monitors installed.
- When switching between AG mode and non-AG mode, the user is notified to remove all the end-to-end and frame monitors installed.

Considerations for the Brocade 6505 and 6510

The Brocade 6505 and 6510 can function in either Fabric OS Native mode or Brocade Access Gateway mode. These switches are shipped in Fabric OS Native mode. All ports on demand (POD) licenses must be present to support Access Gateway.

3 Considerations for the Brocade 6505 and 6510

SAN Configuration with Access Gateway

• Connectivity of multiple devices overview	73
• Direct target attachment	74
• Target aggregation	75
• Access Gateway cascading	76
• Fabric and Edge switch configuration	77
• Connectivity to Cisco fabrics	78
• Rejoining Fabric OS switches to a fabric	79

Connectivity of multiple devices overview

This chapter describes how to connect multiple devices to a switch in Access Gateway (AG) mode, and discusses Edge switch compatibility, target aggregation, direct target attachment, port requirements, NPIV HBA, and interoperability. Switches in AG mode can connect to third-party fabrics with the following firmware versions:

- M-EOSc v9.6.2 or later and M-EOSn v9.6 or later
- Cisco MDS Switches with NX OS v5.x or later

Considerations for connecting multiple devices

Consider the following points when connecting multiple devices to a switch in AG mode:

- AG does not support daisy chaining when two AG devices are connected to each other in a loop configuration.
- Loop devices and FICON channels/control unit connectivity are not supported.
- When a switch is in AG mode, it can be connected to NPIV-enabled HBAs, or F_Ports that are NPIV-aware. Access Gateway supports NPIV industry standards per FC-LS-2 v1.4.

Direct target attachment

FCP targets can directly connect to an AG module instead of through a fabric connection, as illustrated in [Figure 14](#).

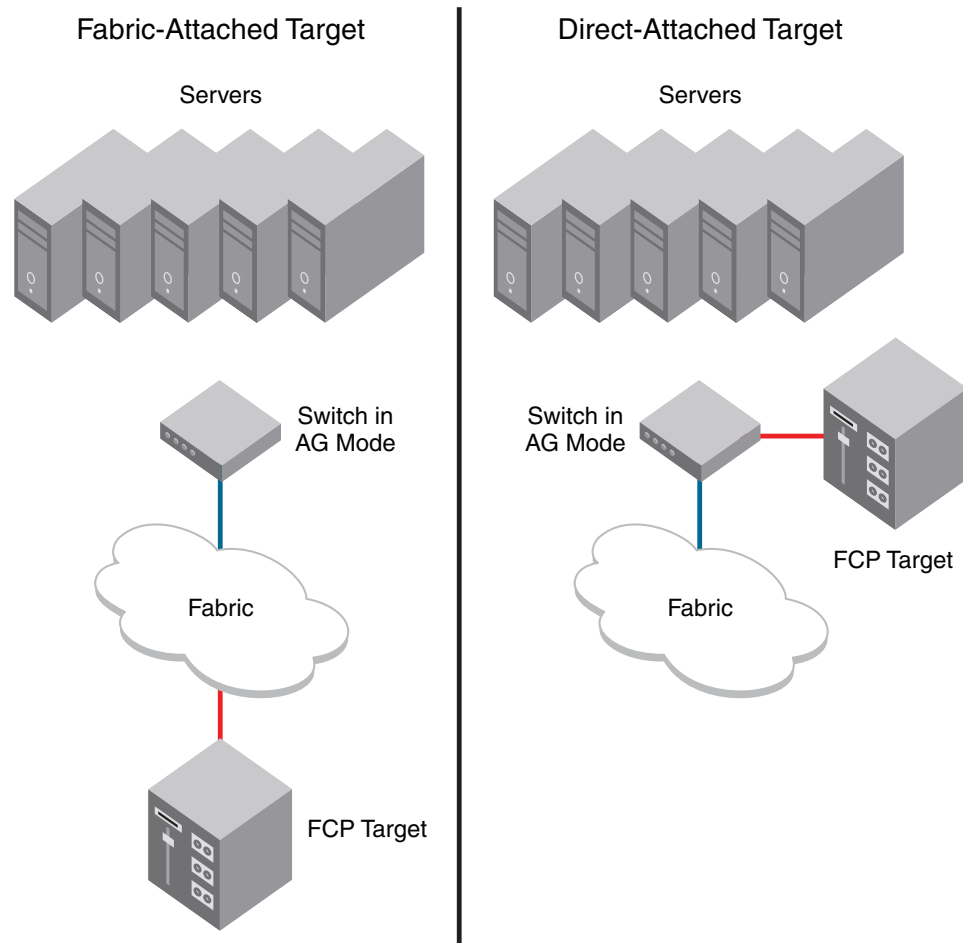

FIGURE 14 Direct target attachment to switch operating in AG mode

Although target devices can be connected directly to AG ports, it is recommended that the switch operating in AG mode be connected to the core fabric.

Considerations for direct target attachment

Consider the following points for direct target attachment:

- Direct target attachment to AG is only supported if the AG module is also connected to a core fabric. A switch module running in AG mode does not provide Name Services on its own, and routing to the target devices must be established by the core fabric.
- Hosts and targets cannot be mapped to the same N_Port.
- Redundant configurations should be maintained so that when hosts and targets fail over or fail back, they do not get mapped to a single N_Port.

- Hosts and targets should be in separate port groups.
- Direct target attachment configurations are not enforced.

Target aggregation

Access Gateway mode is normally used as host aggregation. In other words, a switch in AG mode aggregates traffic from a number of host systems onto a single uplink N_Port. Similarly, many targets can be aggregated onto to a single uplink N_Port, as shown in [Figure 15](#). Target aggregation has many applications. As one example, you can consolidate targets with various lower Fibre Channel speeds (such as 1, 2, or 4 Gbps) onto a single high-speed uplink port to the core fabric. This reduces the number of core fabric ports used by target devices and allows higher scalability.

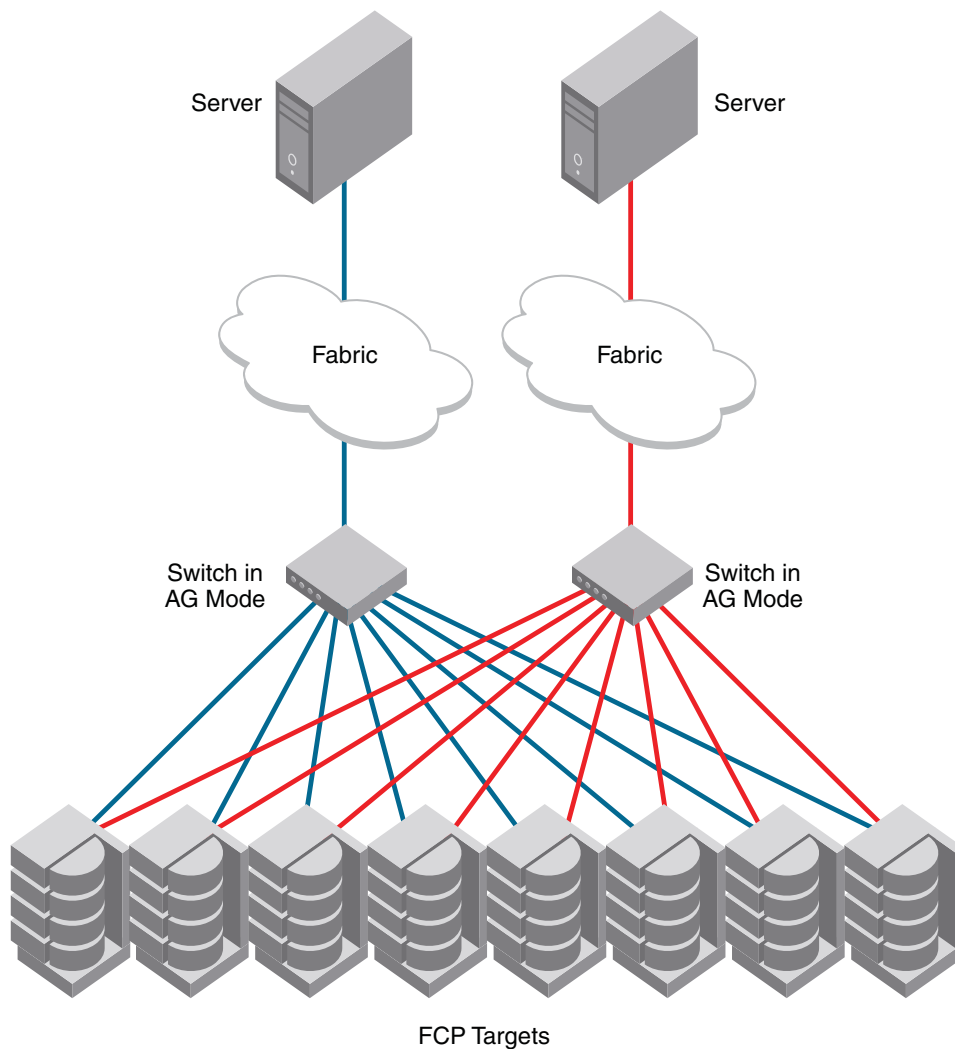

FIGURE 15 Target aggregation

Access Gateway cascading

Access Gateway cascading is an advanced configuration supported in Access Gateway mode. Access Gateway cascading allows you to further increase the ratio of hosts to fabric ports to beyond what a single switch in AG mode can support.

Access Gateway cascading allows you to link two Access Gateway (AG) switches back to back. The AG switch that is directly connected to the fabric is referred to as the Core AG. In this document, the AG switch connected to the device is referred to as the Edge AG. [Figure 16](#) illustrates Access Gateway cascading.

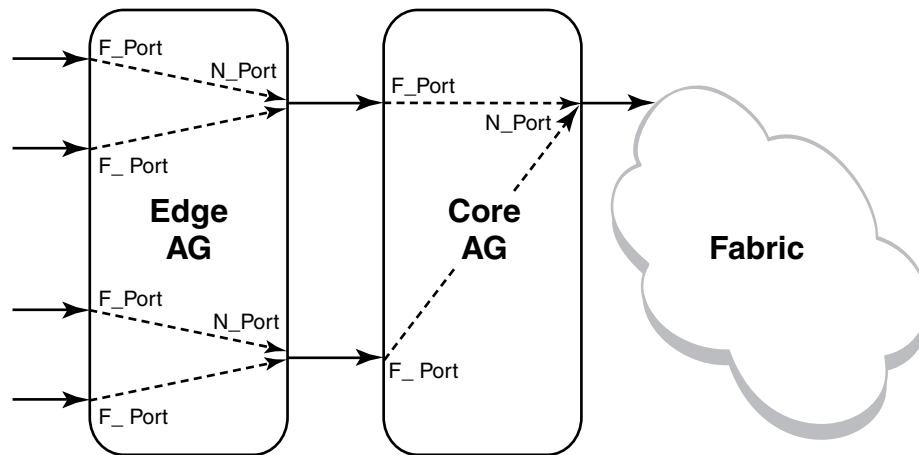

FIGURE 16 Access Gateway cascading

AG cascading provides higher over-subscription because it allows you to consolidate the number of ports going to the main fabric. There is no license requirement to use this feature.

Access Gateway cascading considerations

Note the following configuration considerations when cascading Access Gateways:

- Only one level of cascading is supported. Note that several Edge AGs can connect into a single Core AG to support an even higher consolidation ratio.
- AG trunking between the Edge and Core AG switches is not supported. Trunking between the Core AG switch and the fabric is supported.
- It is recommended that you enable Advanced Device Security (ADS) policy on all AG F_Ports that are directly connected to devices.
- APC policy is not supported when cascading.
- Loopbacks (Core AG N_Port to Edge AG F_Port) are not allowed.
- The `agshow` command issued on the fabric will discover only the Core AG switches. If issued as `agshow --name AG name`, then the F_Ports of both the Core and Edge AG switches will be shown for the Core AG switch.

- Due to high subscription ratios that could occur when cascading AGs, ensure there is enough bandwidth for all servers when creating such configurations. The subscription ratio becomes more acute in a virtual environment.

Fabric and Edge switch configuration

To connect devices to the fabric using Access Gateway, configure the fabric and Edge switches within the fabric that will connect to the AG module using the following parameters. These parameters apply to Fabric OS, M-EOS, and Cisco-based fabrics:

- Install and configure the switch as described in the switch's hardware reference manual before performing these procedures.
- Verify that the interop mode parameter is set to Brocade Native mode.
- Configure the F_Ports on the Edge switch to which Access Gateway is connected as follows:
 - Enable NPIV.
 - Disable long distance mode.
 - Allow multiple logins for M-EOS switches. The recommended fabric login setting is the maximum allowed per port and per switch.
- Use only WWN zoning for devices behind AG.
- If DCC security is being used on Edge switches that directly connect to AG, make sure to include the Access Gateway WWN or the port WWN of the N_Ports. Also include the HBA WWNs that will be connected to AG F_Ports in the switch's Access Control List (ACL). It is recommended to use AG ADS policy instead of the DCC policy on the Edge switch.
- Allow inband queries for forwarded fabric management requests from the hosts. Add the Access Gateway switch WWN to the access list if inband queries are restricted.

Before connecting Access Gateway to classic Brocade switches, disable the Fabric OS Management Server Platform Service to get accurate statistical and configuration fabric data.

Verifying the switch mode

1. Connect to the switch and log in using an account assigned to the admin role.
2. Enter the **switchShow** command to display the current switch configuration.

The following example shows partial output for this command for a switch in the Fabric OS Native mode where **switchMode** displays as Native.

```
switch:admin> switchshow
switchName:      switch
switchType:      76.6
switchState:     Online
switchMode:      Native
switchRole:      Subordinate
switchDomain:     13
switchId:        fffc01
switchWwn:       10:00:00:05:1e:03:4b:e7
zoning:          OFF
switchBeacon:    OFF
```

See [Table 5](#) on page 14 for a description of the port state.

If the switch is in Native mode, you can enable AG mode; otherwise, set the switch to Native mode, and then reboot the switch.

Enabling NPIV on M-EOS switches

1. Connect to the switch and log in as admin on the M-EOS switch.
2. Enable Open Systems Management Server (OSMS) services by entering the following commands.

For the Mi10K switch, enter the following command.

```
fc osmsState vfid state
```

In the command, *vfid* is the virtual fabric identification number. The *state* variable can be **enable** for the enabled state or **disable** for the disabled state.

The *osmsState* variable can be **enable** or **1** for the enabled state or **disable** or **0** for the disabled state.

3. Enable NPIV functionality on the Edge fabric ports so that multiple logins are allowed for each port. Enter the following command on the M-EOS switch to enable NPIV on the specified ports.

```
config NPIV
```

Your M-EOS switch is now ready to connect.

NOTE

You can run the **agshow** command to display Access Gateway information registered with the fabric. When an Access Gateway is exclusively connected to non-Fabric-OS-based switches, it will not show up in the **agshow** output on other Brocade switches in the fabric.

Connectivity to Cisco fabrics

When connecting a switch in Access Gateway mode to a Cisco fabric, you need to make sure that NPIV is enabled on the connecting switch and that Fabric OS v3.1 or later is used.

Enabling NPIV on a Cisco switch

1. Log in as admin on the Cisco MDS switch.
2. Enter the **show version** command to determine if you are using the correct SAN operating system version and if NPIV is enabled on the switch.
3. Enter the following commands to enable NPIV:

```
configure terminal  
npiv enable
```

4. Press **Ctrl-Z** to exit.

5. Enter the following commands to save the MDS switch connection:

```
copy
run
start
```

Your Cisco switch is now ready to connect to a switch in Access Gateway mode.

Rejoining Fabric OS switches to a fabric

When a switch reboots after AG mode is disabled, the Default zone is set to no access. Therefore, the switch does not immediately join the fabric to which it is connected. Use one of the following methods to rejoin a switch to the fabric:

- If you saved a Fabric OS configuration before enabling AG mode, download the configuration using the **configDownload** command.
- If you want to rejoin the switch to the fabric using the fabric configuration, use the following procedure.

To rejoin the Fabric OS switch to a fabric, perform the following steps:

1. Connect to the switch and log in using an account assigned to the admin role.
2. Enter the **switchDisable** command to disable the switch.
3. Enter the **defZone --allAccess** command to allow the switch to merge with the fabric.
4. Enter the **cfgSave** command to commit the Default zone changes.
5. Enter the **switchEnable** command to enable the switch and allow it to merge with the fabric.

The switch automatically rejoins the fabric.

Reverting to a previous configuration

1. Connect to the switch and log in using an account assigned to the admin role.
2. Enter the **switchDisable** command to disable the switch.
3. Enter the **configDownload** command to revert to the previous configuration.
4. Enter the **switchEnable** command to bring the switch back online.

The switch automatically joins the fabric.

4 Rejoining Fabric OS switches to a fabric

Troubleshooting

Table 12 provides troubleshooting instructions for Access Gateway.

TABLE 12 Troubleshooting

Problem	Cause	Solution
Switch is not in Access Gateway mode	Switch is in Native switch mode	<p>Disable switch using the switchDisable command.</p> <p>Enable Access Gateway mode using the ag --modeenable command.</p> <p>Answer yes when prompted; the switch reboots.</p> <p>Log in to the switch.</p> <p>Display the switch settings using the switchShow command. Verify that the field switchMode displays Access Gateway mode.</p>
NPIV disabled on Edge switch ports	Inadvertently turned off	<p>On the Edge switch, enter the portCfgShow command.</p> <p>Verify that NPIV status for the port to which Access Gateway is connected is ON.</p> <p>If the status displays as “–” NPIV is disabled. Enter the portCfgNpivPort port_number command with the enable option to enable NPIV.</p> <p>Repeat this step for each port as required.</p>
Need to reconfigure N_Port and F_Ports	Default port setting not adequate for customer environment	<p>Enter the portCfgShow command.</p> <p>For each port that is to be activated as an N_Port, enter the portCfgNport port_number command with the 1 option.</p> <p>All other ports remain as F_Ports.</p> <p>To reset the port to an F_Port, enter the portCfgNpivPort port_number command with the disable option.</p>
LUNs are not visible	<p>Zoning on fabric switch is incorrect.</p> <p>Port mapping on Access Gateway mode switch is incorrect.</p> <p>Cabling not properly connected.</p>	<p>Verify zoning on the Edge switch.</p> <p>Verify that F_Ports are mapped to an online N_Port. See “Access Gateway default port mapping” on page 17.</p> <p>Perform a visual inspection of the cabling; check for issues such as wrong ports, twisted cable, or bent cable. Replace the cable and try again. Ensure the F_Port on AG module is enabled and active.</p>
Failover is not working	Failover disabled on N_Port.	<p>Verify that the failover and failback policies are enabled, as follows:</p> <p>Enter the ag --failoverShow command with the <i>port_number</i> option.</p> <p>Enter the ag --failbackShow command with the <i>port_number</i> option.</p> <p>Command returns “Failback (or Failover) on N_Port <i>port_number</i> is supported.”</p> <p>If it returns, “Failback (or Failover) on N_Port <i>port_number</i> is not supported.” Refer to “Adding a preferred secondary N_Port (optional)” on page 52.</p>

A Troubleshooting

TABLE 12 Troubleshooting (Continued)

Problem	Cause	Solution
Access Gateway is mode not wanted	Access Gateway must be disabled.	Disable switch using the switchDisable command. Disable Access Gateway mode using the ag --modeDisable command. Answer yes when prompted; the switch reboots. Log in to the switch. Display the switch settings using the switchShow command. Verify that the field switchMode displays Fabric OS Native mode.
“Login Rejected by FC stack” messages on console may be seen during F_Port and N_Port disruptions on Brocade IB 8470 in AG mode.	The CNA host is retrying a login before the switch has finished processing a previous fabric logout (LOGO) attempt.	Messages display as designed. After the switch has completed LOGO processing, it will accept another login.

Index

A

- Access Gateway
 - cascading, 76
 - comparison to standard switches, 9
 - compatible fabrics, 1
 - connecting devices, 73
 - connecting two AGs, 76
 - description, 1
 - displaying information, 78
 - features, 3
 - limitations, 11
 - mapping description, 16
 - port types, 9
- Access Gateway mode
 - comparison, 2, 3
 - disabling, 14
 - port types, 9
 - supported firmware versions, 73
 - terms, xvii
 - verifying, 14
- adaptive networking, 65
 - AG considerations, 67
 - upgrade and downgrade considerations, 66
- adding devices to fabric, 38
- address Identifier, 60
- admin domain, 64
- ADS Policy
 - adding devices, 38
 - displaying devices, 38, 39
 - enabling, 37
 - removing devices, 38
- Advanced Performance Monitoring, 69
- APC Policy
 - disabling, 40
 - rebalancing F_Ports, 44
 - support for port groups, 43
- area assignment, 62

- authentication
 - considerations, 9
 - device, 6
 - limitations, 9
 - policy modes, 7
 - related commands, 8
 - support, 6
- authentication, limitations, 62

B

- behavior, failover policy, 56
- Brocade 6505 and 6510, AG considerations, 71

C

- Cisco fabric
 - connectivity, 78
 - enabling NPIV on Cisco switch, 78
- code, xv

commands

- ag --addwwnfailovermapping, 53
- ag --addwwnpgmapping, 25
- ag --delwwnfailovermapping, 54
- ag --delwwnpgmapping, 25
- ag --failbackEnable, 56, 57
- ag --failbackShow, 56, 81
- ag --failoverDisable, 54
- ag --failoverEnable, 54, 55
- ag --failoverShow, 54, 81
- ag --mapAdd, 20
- ag --mapDel, 20
- ag --mapShow, 14, 20
- ag --modeDisable, 14, 82
- ag --modeEnable, 13, 81
- ag --modeShow, 14
- ag --policydisable wwnloadbalance, 47
- ag --policyenable wwnloadbalance, 47
- ag --wwnmapping, 25, 26, 53, 54
- ag --wwnmappingdisable, 26
- ag --wwnmappingenable, 26
- ag --wwnmapshow, 25, 26

- cfgSave, 79
- configDownload, 79
- configUpload, 24
- defZone --allAccess, 79
- portCfgNpivPort, 81
- portCfgNport, 31, 81
- portCfgShow, 81
- switchDisable, 14, 79, 81, 82
- switchEnable, 79
- switchMode, 81, 82
- switchShow, 14, 20, 77, 81, 82

compatibility, fabric, 77

configurations

- enabling switch, 79
- limitations with configdownload command, 64
- merging switch with fabric, 79
- re-joining switch to fabric, 79
- saving, 79
- using configdownload command, 79

D

D_Port

- configurations supported, 32
- description, 9, 10, 32
- saving port mappings, 33
- tests, 32

daisy chaining, 73

DCC policy

- adding WWN, 60
- enabling, 60
- limitation creating TA, 64

default area, removing ports, 63

device load balancing, 44

device load balancing policy, 47

- APC policy, 48
- considerations, 48
- disabling, 47
- enabling, 47
- trunking, 48, 65

device mapping, 15

- adding a secondary N_Port, 53

- adding devices to N_Ports, 25

- considerations, 29

- disabling, 26

- enabling, 26

- failover, 53

- feature overview, 22

- pre-provisioning, 27

- removing secondary N_Port, 54

- static vs. dynamic mapping, 24

- to port group, 24

- to ports, 25

- VMware configuration, 28

- VMware considerations, 28

devices

- attaching multiple devices, 73

disabling switch

- switchDisable, 79

domain, Index, 59

downgrading, 62

downgrading considerations, 39, 40

duplicate PWWWN handling during login, 68

dynamic vs. static mapping, 24

E

Edge switch

- FLOGI, 77

- long distance mode setting, 77

- NPIV, 77

- settings, 77

end to end monitors, 69

ensure port online state, 31

F

F_Port

- adding external port on embedded switch, 30
- description, 9
- mapping, example, 16
- maximum number mapped to N_Port, 30
- settings, Edge switch, 77
- shared area ports, 60
- trunking setup, 59

fabric

- compatibility, 77
- inband queries, 77
- join, 79
- logins, 77
- management server platform, 77
- zoning scheme, 77

Fabric OS features supported, 3

Fabric OS management server platform service settings, 77

failback policy

- upgrade and downgrade considerations, 57

failback policy example, 51, 55

failover

- device mapping, 53

failover example, 51

failover policy

- behavior, 52
- configurations for port mapping, 51
- enabling, 54
- example, 52, 56
- port mapping, 50

fast write limitation, 63

FICON, F_Port trunk ports, 63

Flow Monitor, 68

Flow Vision, 68

frame monitors, 70

H

HA sync, TA present, 62

I

ICL ports, limitations, 64

inband queries, 77

initiator and target port considerations, 19

J

join fabric, 79

L

limitations

- device load balancing, 48
- direct connections to target devices, 11
- loop devices not supported, 11
- login balancing considerations, 45
- long distance mode, Edge switch, 77

M

managed fabric name monitoring

- disabling, 45
- displaying current timeout value, 46
- enabling, 45
- setting timeout values, 46

management server, 62

mapping

- considerations, 28
- device, 15
- device to port groups, 24
- devices to ports, 25
- example, 16
- port, 15
- ports, 15

mapping priority, 16

masterless trunking, 63

M-EOS switch, enabling NPIV, 78

monitors

- end to end, 69
- frame, 70

N

N_Port

- configurations, 30
- description, 9
- displaying configurations, 31
- failover in a PG, 46
- mapping example, 16
- masterless trunking, 58
- maximum number supported, 30
- multiple trunk groups, 65
- trunk groups, 65
- unlock, 31
- unlocking, 31

N_Port configurations

- displaying, 31

N_Ports

- unlocking, 31

native switchMode, 77

non disruptive, 62

NPIV

- Edge switch, 77
- enabling on Cisco switch, 78
- enabling on M-EOS switch, 78
- login limit, 67
- support, 73

O

optional features, *xviii*

P

per port NPIV login limit, 67

performance monitoring

- Flow Monitor, 68
- legacy monitoring features, 69

Persistent ALPA

- support, 48

persistent ALPA

- clearing ALPA values, 50
- considerations, 50
- deleting hash table data, 49
- disabling, 49
- enabling, 48
- flexible ALPA value, 48
- reboot, 50
- stringent ALPA value, 48
- tables, 49
- value types, 48

persisting port online state, 31

policies

- advance device security, 36
- enabling DCC policy, 60
- enforcement matrix, 36
- port grouping, 41
- showing current policies, 35
- using policyshow command, 35

port

- comparison, 9
- mapping, 15
- requirements, 73
- types, 9

port group

- add N_Port, 42, 44
- create, 44
- delete N_Port, 42
- disabling, 43
- enabling logging balancing mode, 44
- login balancing mode, 43
- managed fabric name monitoring mode, 44
- remove port group, 42
- rename, 43

Port Grouping policy

- using portcfgnport command, 31

port grouping policy

- considerations, 46
- downgrading considerations, 47

port mapping, 15

- adding F_Ports to N_Ports, 20
- adding ports, 20
- adding secondary N_Port, 52
- considerations for initiator and target ports, 19
- default F_Port-to-N_Port, 17
- deleting secondary N_Port, 53
- maximum number of F_Ports, 30
- removing F_Ports from N_Ports, 20

Port mirroring, not supported, 63

port state, description, 14

port swap, not swapping TA, 63

- port types, limitations, 62
- portcfgpersistentenable command, 31
- preferred secondary N_Port
 - login balancing mode, 52
 - online, 51
- PWWN
 - duplicate handling during login, 68
 - format, 65
 - sharing TA trunk group, 62

Q

- QoS
 - firmware downgrade, 66
 - ingress rate limiting, 66
 - SID/DID traffic prioritization, 65

R

- removing devices from switch, 38
- removing trunk ports, 62
- requirements, ports, 73

S

- settings
 - FLOGI, 77
 - inband queries, 77
 - management server platform, 77
 - zone, no access, 79
- static vs. dynamic mapping, 24
- supported hardware and software, xiv
- switch mode, verify, 77

T

- terms, xvii
- trunk area
 - assign, 60
 - configuration management, 59
 - disabling, 63
 - remove ports, 60
 - standby CP, 62
 - using the porttrunkarea command, 63
- trunk groups, create, 59
- trunk master, limitation, 63

- trunking, 58
 - configuring on edge switch, 58
 - considerations in AG module, 65
 - considerations on edge switch, 62
 - disabling, 61
 - enabling, 61, 63
 - license, 58

U

- unlock N_Port, 31
- upgrading, 62

V

- VMware configuration for device mapping, 28

Z

- zoning
 - schemes, 77
 - setting, 79

